

Answers and Teachers' Notes

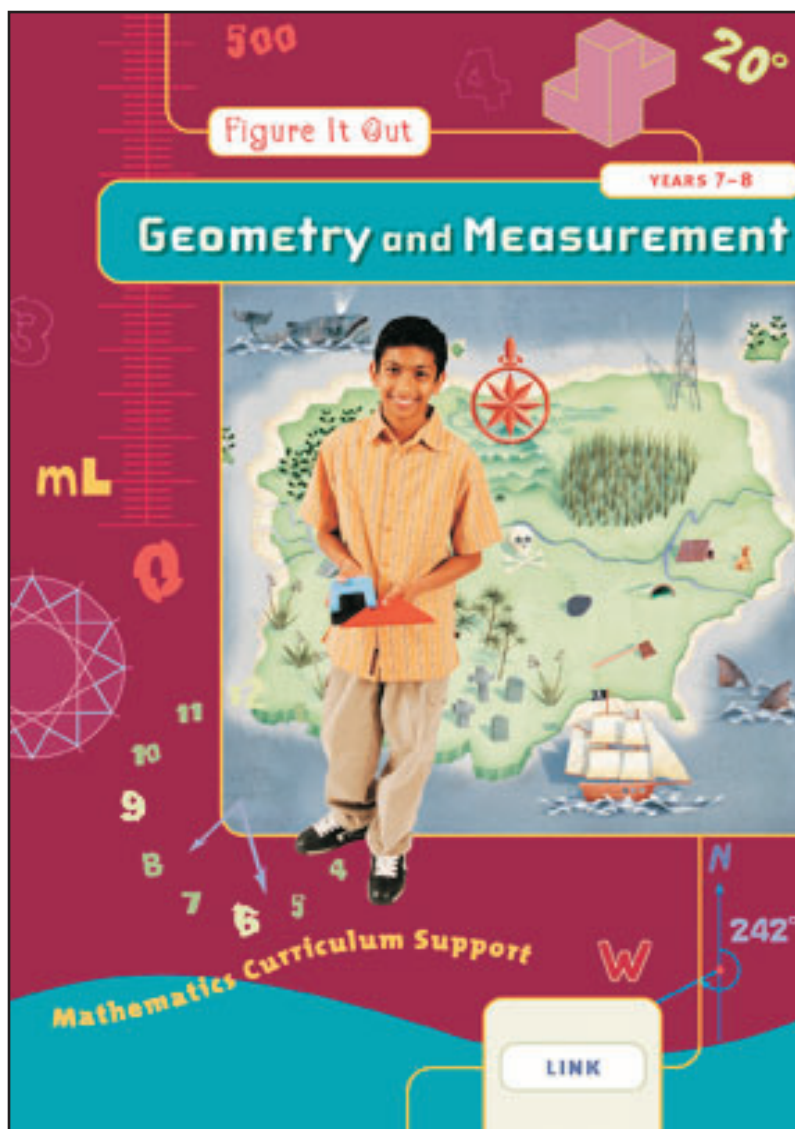

MINISTRY OF EDUCATION
Te Tāhuhu o te Mātauranga

CONTENTS

Introduction	2
Answers	3
Teachers' Notes	9
Copymasters	37

Geometry and Measurement is one of five Link books in the Figure It Out series. The others are *Number: Books One and Two*, *Number Sense: Book One*, and *Algebra: Book One*.

These books have been developed specifically for students in years 7–8 who need further help with level 2 and 3 concepts and skills. This particular book aims to strengthen students' understandings about measurement and spatial relationships, attach meaning to units, aid the development of estimation skills, and encourage the use of mathematical language.

All Figure It Out books set activities in real-life and imaginary contexts that should appeal to students. The real-life contexts reflect many aspects of life in New Zealand, and the young people portrayed in illustrations and photos reflect our ethnic and cultural diversity.

The activities may be used as the focus for teacher-led lessons, for students working in groups, or for independent activities. But bear in mind that the Figure It Out series is a resource, not a set of textbooks. This means that if you are setting an activity to be done independently, you should check that you have done whatever prior teaching is needed.

Teachers sometimes report that their students have difficulty understanding the words on the page. We are very mindful of this and try to keep written instructions as brief and as clear as possible, but to create a context and pose questions, some words must be used. It is important that mathematical language and terminology be deliberately taught.

The Answers section of the *Answers and Teachers' Notes* that accompany each student book includes full answers and explanatory notes. Students can use them for self-marking, or you can use them for teacher-directed marking. The teachers' notes for each activity include achievement objectives, a commentary on the mathematics involved, and suggestions on teaching approaches. The *Answers and Teachers' Notes* are also available on Te Kete Ipurangi (TKI) at www.tki.org.nz/r/maths/curriculum/figure

Where applicable, each page starts with a list of the equipment needed. Encourage the students to be responsible for collecting this equipment and returning it at the end of the session.

Encourage your students to write down how they did their investigations or found solutions, drawing diagrams where appropriate. Discussion of strategies and answers is encouraged in many activities, and you may wish to ask your students to do this even where the instruction is to write down the answer.

The ability to communicate findings and explanations, and the ability to work satisfactorily in team projects, have also been highlighted as important outcomes for education. Mathematics education provides many opportunities for students to develop communication skills and to participate in collaborative problem-solving situations.

Mathematics in the New Zealand Curriculum, page 7

Students will have various ways of solving problems or presenting the strategy they have used and the solution. You should acknowledge successful ways of solving questions or problems, and where more effective or efficient strategies can be used, encourage the students to consider their merits.

As for all books in the series, the material in *Geometry and Measurement* has been developed by mathematics educators and trialled in classrooms.

Answers

Geometry and Measurement

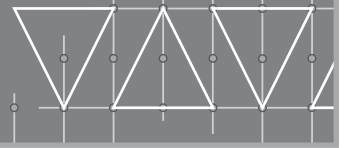

Page 1

Triangle Teaser

ACTIVITY ONE

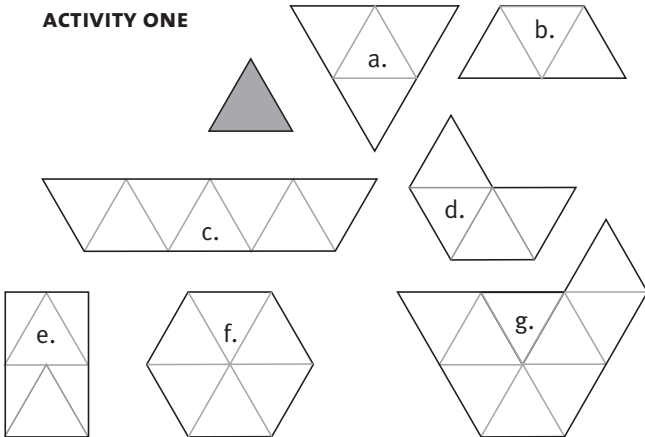

- a. 4
- b. 3
- c. 7
- d. 4
- e. 4
- f. 6
- g. 9

ACTIVITY TWO

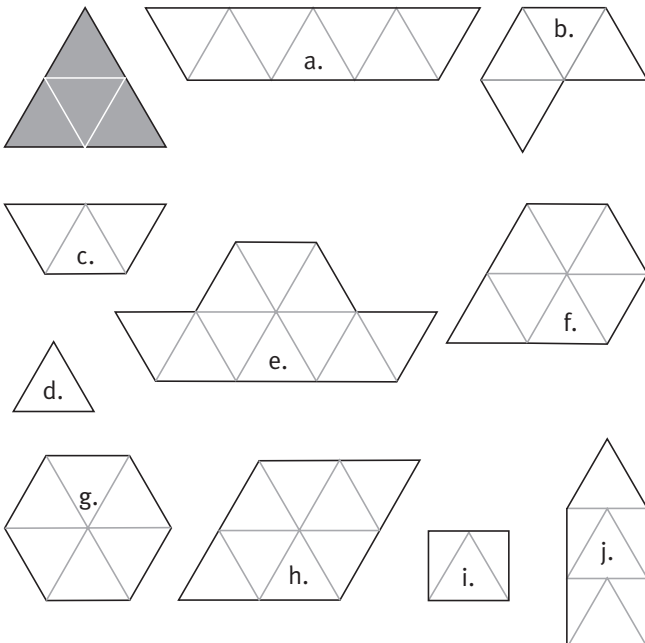

- a. $\frac{7}{4} = 1\frac{3}{4}$
- b. $\frac{4}{4} = 1$
- c. $\frac{3}{4}$
- d. $\frac{1}{4}$
- e. $\frac{10}{4} = 2\frac{1}{2}$
- f. $\frac{7}{4} = 1\frac{3}{4}$
- g. $\frac{6}{4} = 1\frac{1}{2}$
- h. $\frac{8}{4} = 2$
- i. $\frac{2}{4} = \frac{1}{2}$
- j. $\frac{5}{4} = 1\frac{1}{4}$

Page 2

Punch a Pattern

ACTIVITY

1. Here are the folding lines you will need to make for each of the patterns:

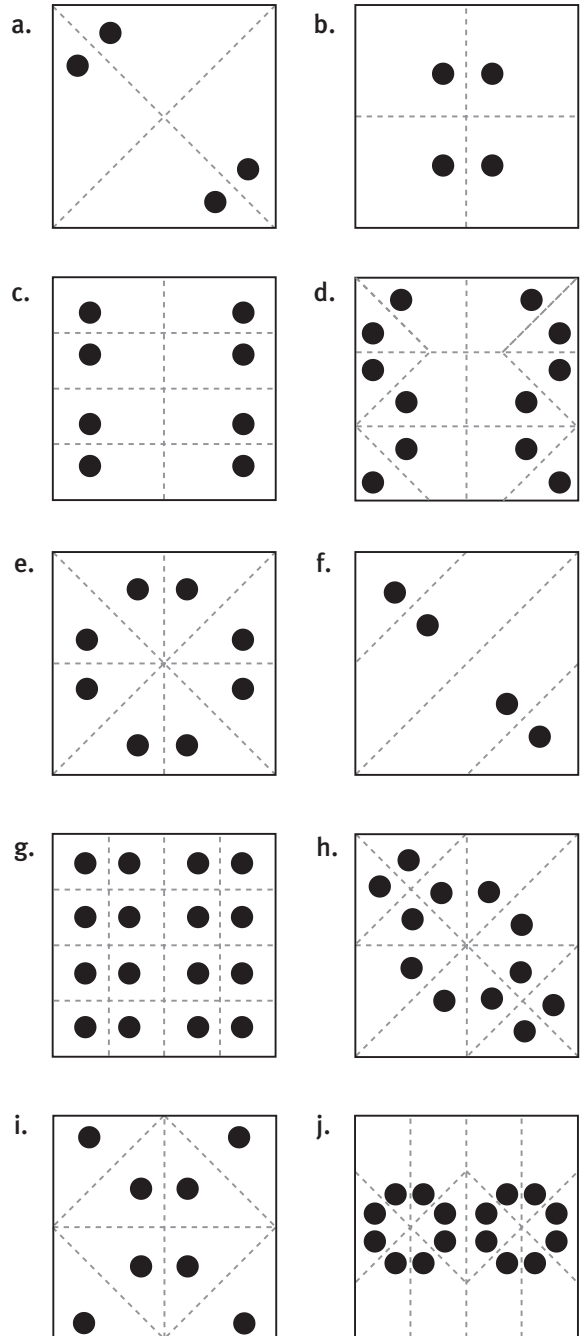

2. a.-b. Practical activity

ACTIVITY ONE

One of the blocks must have the numbers 0, 1, and 2 on it, and the other must have 1, 2, and 3 on it. Each of the other numbers (4, 5, 6, 7, 8, and 9) can be painted on any of the remaining faces of either block. The diagram shows possible nets for two cardboard calendar dice. There are many ways of arranging the numbers so that they work.

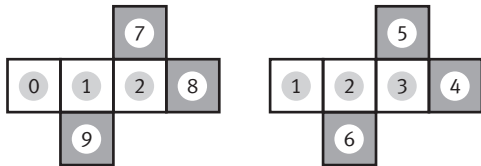

The numbers 4–9 can go on either dice.

ACTIVITY TWO

Orange

ACTIVITY THREE

1. For a 3 x 3 x 3 cube:

3 x 3 x 3 cube	Number of painted faces				Total
	1	2	3	None	
Number of cubes	6	12	8	1	27

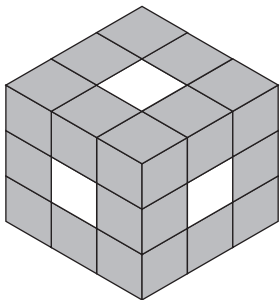

1 painted face
(1 cube on each of the 6 faces)

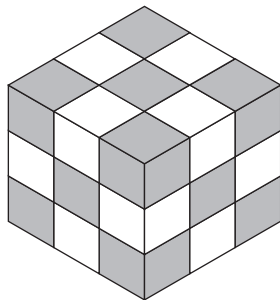

2 painted faces
(1 cube on each of the 12 edges)

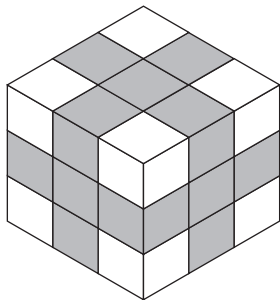

3 painted faces
(1 cube at each of the 8 vertices)

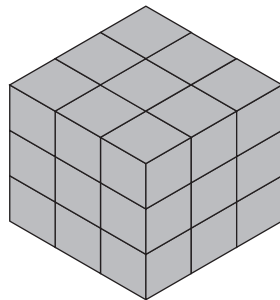

0 painted faces
(1 cube hidden right in the centre of the big cube)

2. For a 4 x 4 x 4 cube:

4 x 4 x 4 cube	Number of painted faces				Total
	1	2	3	None	
Number of cubes	24	24	8	8	64

Compare this illustration with the one above. Can you see patterns developing?

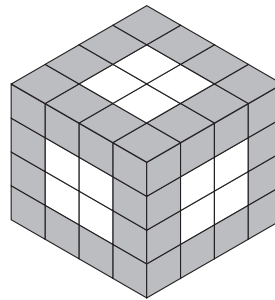

1 painted face
(4 cubes on each of the 6 faces)

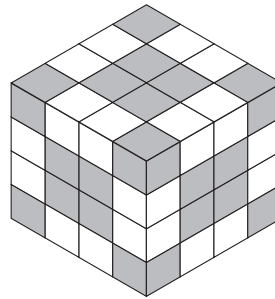

2 painted faces
(2 cubes on each of the 12 edges)

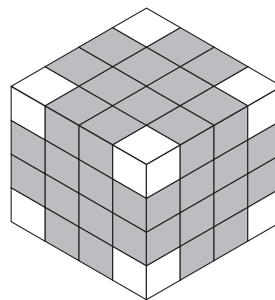

3 painted faces
(1 cube at each of the 8 vertices)

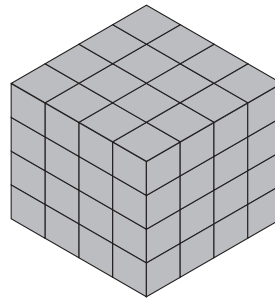

0 painted faces
(8 cubes hidden right in the centre of the big cube)

For a 5 x 5 x 5 cube:

5 x 5 x 5 cube	Number of painted faces				Total
	1	2	3	None	
Number of cubes	54	36	8	27	125

No Looking!

ACTIVITY ONE

1. Descriptions will vary. You could start by saying how many cubes there are in total and what colours. You could then describe the model starting from the bottom layer and working up.
2. Practical activity

ACTIVITY TWO

1. Practical activity. Start by saying which of the 9 squares your chosen figure goes into. Then say how many shapes (and what kind) go to make up the figure. You could suggest that the other person imagines the square divided into a 2 x 2 or 3 x 3 grid, depending on the figure. This will help you explain where to place objects and how big they should be. Or you could estimate sizes and distances in millimetres or centimetres. Describe what lines up with what, where the parts of the figure cut across each other, and so on. With practice, you should find that your descriptions get better and easier to follow.

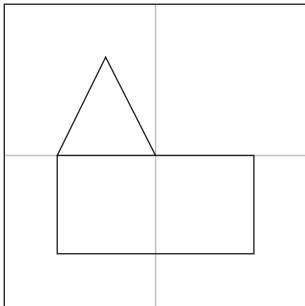

It may help to imagine the square divided into quarters when describing and drawing this figure.

2. Practical activity

Cantitowers

ACTIVITY

1. Practical activity

a.

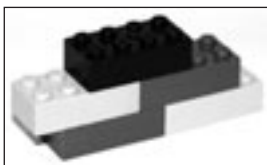

b.



c.



d.

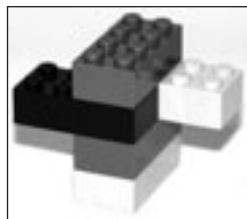

e.

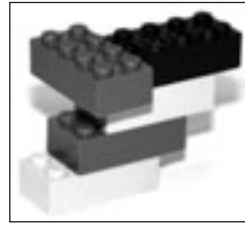

f.



2. Practical activity. Answers will vary.
3. Practical activity

a.

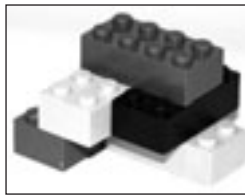

b.

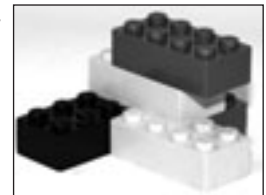

Open and Shut

ACTIVITY

1. Predictions will vary.
2. These nets can be made into open boxes: a, c, d, e, g, i, j, k.

Chessboard Challenges

ACTIVITY

Puzzle One

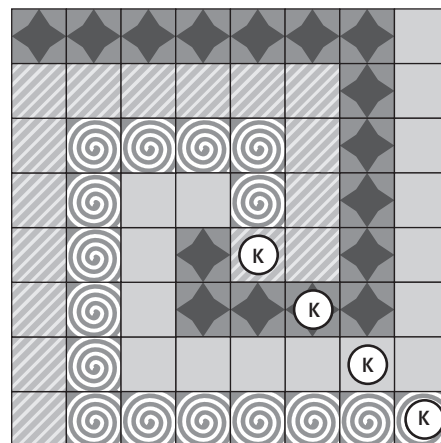

Puzzle Two

Here are four solutions. There are 12 altogether (not counting rotations and reflections).

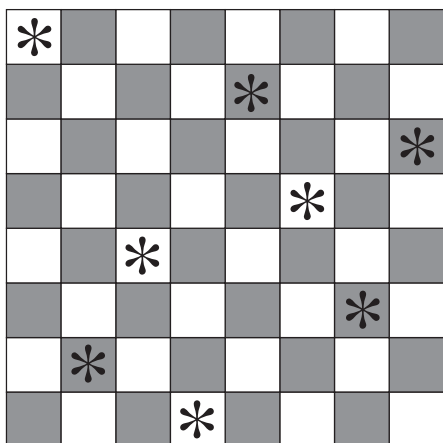
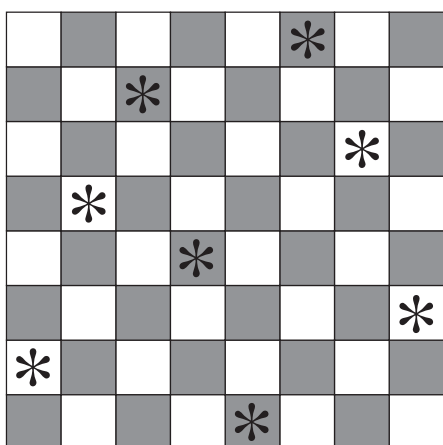
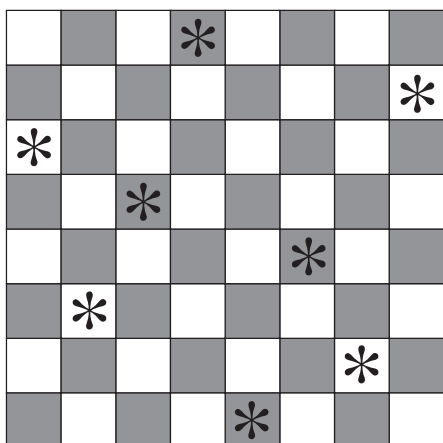
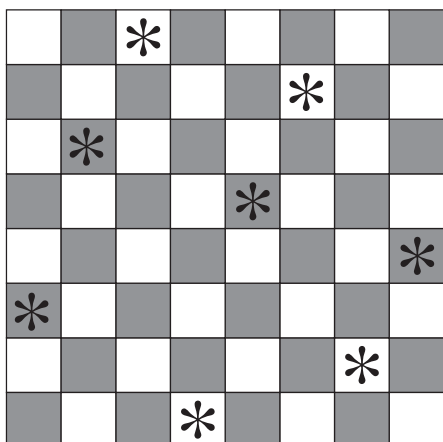

Pages 10–11 Secret Scales

ACTIVITY ONE

1.–2. Practical activities

ACTIVITY TWO

1.–2. Practical activities

3. Answers will vary. You might include: angle (degrees and minutes), temperature (degrees Celsius), electricity (volts, amps, ohms), force (newtons), speed (m/s, km/h), light (lumens), pressure (pascals, millibars, atmospheres), acceleration (m/s²), sound (decibels), fuel consumption (L/100 km).

Pages 12–13 Judgment Calls

ACTIVITY ONE

1.–2. Practical activities

ACTIVITY TWO

1.–3. Practical activities

ACTIVITY THREE

1. Practical activity

2. a. Practical activity

b. Answers will vary. You may find that it is reasonably easy to compare the mass of objects of similar density, like two stones, but not so easy where the densities are quite different.

ACTIVITY FOUR

Answers will vary.

Page 14 What's the Connection?

ACTIVITY

1. a. 1 000 mL or 1 L

b. 1 000 g or 1 kg

c. 1 L of water will fill a 1 000 cm³ container and will weigh 1 kg. Or, 1 000 mL of water occupies 1 000 cm³ and weighs 1 000 g.

2. a.–b. Practical task. As examples, the water in a 1.5 L bottle will weigh 1 500 g (1.5 kg) and 250 mL of water will weigh 250 g.

3. Practical task. A cubic metre container filled with water would hold 1 000 L and weigh 1 000 kg (1 tonne).

ACTIVITY

1. Answers will vary. One possible definition is: “Estimation is when we work out a rough (but good enough) answer.” Some reasons why we estimate:
 - i. In the circumstances, an estimate may be all we need or want.
 - ii. For some practical reason, it may be difficult to get exact numbers or measurements.
 - iii. We don’t have a calculator with us, and the numbers are too difficult to work with in our head.
 - iv. We’ve worked out the answer on our calculator and want to check if it is sensible.
2. Answers and methods will vary, even for exactly the same challenge (for example, two students estimating the height of the same tall tree).
3. Practical task. The important thing is that you can explain to your classmates how you arrived at your estimates and why you chose the methods you did.
4. Practical task

Pages 16–17 Olive Toil

ACTIVITY

- a. False. 600 trees each with 20 kg of olives = $600 \times 20 = 12\,000$ kg.
- b. False. 2 trees would give $20 \times 2 = 40$ kg of olives. 1 bin holds only 10 kg, so they would need 4 bins for the olives from 2 trees.
- c. True. 12 000 kg of olives needs to be shared out into 10 kg bins. $12\,000 \div 10 = 1\,200$ bins.
- d. True. 8 hours at 250 kg per hour = $8 \times 250 = 2\,000$ kg.
- e. False. 12 000 kg at 2 000 kg a day = $12\,000 \div 2\,000 = 6$ days.
- f. True. 14 400 L of oil produced in total and shared between 10 growers = $14\,400 \div 10 = 1\,440$ L each.
- g. True. $12\% \text{ of } 600 \times 20 = 0.12 \times 1\,200 = 1\,440$ L. Either calculate $1\,440 \text{ L} \div 0.25 \text{ L} = 5\,760$ bottles, or reason that as 1 L will fill 4 x 250 mL bottles, 1 440 L will fill $1\,440 \times 4 = 5\,760$ bottles.
- h. False. 5 760 bottles are shared into cartons that fit 20 bottles each. $5\,760 \text{ bottles} \div 20 = 288$ cartons needed.

- i. True. 20 bottles each of 250 mL = $20 \times 250 = 5\,000$ mL or 5 L.
- j. True, but only if Joan and Dave can sell all their oil at \$20 a bottle. $5\,760 \times 20 = \$115,200$
- k. False. If Joan and Dave can sell all their oil at \$20 per bottle, their total earnings will be \$115,200. Earnings divided by number of trees is $115\,200 \div 600 = \$192$ per tree.

ACTIVITY

1. a. Predictions will vary.
 - b. Predictions will vary. Multiply the number of A4 sheets by 600.
2. Methods will vary. None will give a very exact answer. Rather obviously, you only need to measure one hand (for example) and then double the result for the area of both hands. You may also find that covering the surface with small squares or rectangles of paper of known size (cut from square grid paper) gives a better result than measuring with bigger units.
3. a. Practical task
 - b. Your answer won’t be very accurate, but your method may give a better result than the methods used by some of your classmates.
 - c.–d. Practical tasks
4. Practical tasks
5. Answers will vary. It is likely that you have found that measuring the surface area of 3-D objects is difficult if they don’t have flat surfaces and/or are irregular.

ACTIVITY

Practical activity

ACTIVITY

1. a. 45 km
b. 60 km
c. About 40 km
d. About 55 km
2. a. 40 km due south
b. 45 km due north
c. 30 km north-west
d. 60 km north-east
3. Pihikete and Melthorn, Tewano and Wīwī
4. a. 180°
b. 135°
c. 230°
d. 270°
5. a. 10 min. (90 km in an hour is the same as 30 km in 20 min or 15 km in 10 min.)
b. 100 km/h. 60 km in 36 min is the same as 10 km in 6 min or 100 km in 60 min, which is 100 km/h.
c. Melthorn or Pihikete. 90 km/h is the same as 45 km in 30 min. Both these towns are 45 km away “as the crow flies”.
6. Answers will vary. Possibilities include: the road detours to cross a river or avoid a mountain, a winding road, a steep road, 50 km/h zones, a narrow or unsealed road, a dangerous road, a lot of traffic on the road, bad weather, a breakdown, or stopping for someone who is feeling carsick.

ACTIVITY

If you unjumble the letters given by the co-ordinates, you will get these words:

U N D E R F L A X

To find exactly which of the flax bushes the treasure is under, you will need to work out the rest of the poem yourself! (When you’ve worked it out, you will have the co-ordinates of the correct flax bush. You’ll know that you have got it right without an answer to tell you!)

GAME

A game involving co-ordinates

ACTIVITY

1. The sort of thing Courtney describes happens every time a person crosses the International Date Line. If they cross from west to east, they gain 24 hours; if they cross from east to west, they lose 24 hours. Courtney left the evening before her birthday and travelled for 12 hours, so she should have arrived on the morning of her birthday, but because she crossed the Date Line on the way, it wasn’t her birthday, but the day after it.
2. This is a common problem. London is 12 hours behind New Zealand, so when it is 10 a.m.–7 p.m. there (good times for phoning), it is 10 p.m.–7 a.m. in New Zealand (good times for sleeping). 8–10 a.m. in London is 8–10 p.m. here (and vice versa), which is a time slot likely to be suitable for a phone conversation at either end.
3. a. Practical activity
b. Practical activity. Don’t forget to note the day as well as the time. (Example: ringing Vancouver in Canada, which is 20 hours behind New Zealand. Take off 24 hours, which makes the time 9.00 a.m. on Tuesday. Add 4 hours back on to this, which makes the time in Vancouver 9.00 + 4.00 = 1.00 p.m. on Tuesday.)
c. Practical activity. (Example: ringing Sāmoa, which is 23 hours behind New Zealand. Add 24 hours to the time in Sāmoa, which gives a time of 6.00 p.m. here on Thursday. Take 1 hour off this, which means that 6.00 p.m. Wednesday in Sāmoa is 5.00 p.m. Thursday in New Zealand.)

INVESTIGATION

Answers will vary.

Teachers' Notes

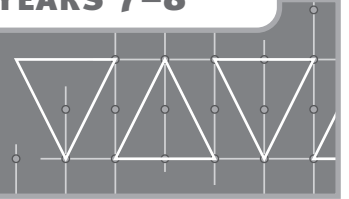

Overview

Geometry and Measurement

Title	Content	Page in students' book	Page in teachers' book
Triangle Teaser	Using a unit shape to compare areas	1	10
Punch a Pattern	Investigating symmetry	2	11
Out of Sight	Using visible information to work out hidden details	3	12
No Looking!	Describing simple objects, using the language of geometry	4–5	14
Cantitowers	Building solids from diagrams showing only side views	6–7	17
Open and Shut	Exploring nets of simple containers	8	19
Chessboard Challenges	Using symmetry to solve puzzles	9	20
Secret Scales	Exploring attributes, measurement, and scales	10–11	22
Judgment Calls	Carrying out practical measuring tasks involving length, mass, and time	12–13	23
What's the Connection?	Exploring connections between the measures for mass and volume	14	25
Eyeball Estimates	Practising estimation	15	27
Olive Toil	Working with units of mass, volume, time, and money	16–17	29
You're Covered!	Investigating the surface area of irregular solids	18	30
Going Places	Creating instructions using distance and turn	19	31
Crow Ks	Using compass points and bearings to specify location	20–21	32
Map Mysteries	Specifying location, using grid references	22–23	34
Sorry to Disturb You!	Understanding how geography influences time	24	35

Achievement Objectives

- perform measuring tasks, using a range of units and scales (Measurement, level 3)
- solve practical problems which require finding fractions of whole number and decimal amounts (Number, level 3)

AC
EA
AA
AM
AP

In these two activities, students estimate the areas of shapes by visualising how many triangular units it would take to cover them. To successfully complete the activities, students need an understanding of fractional numbers, including improper fractions (those greater than 1), how these can be represented visually, and how to add fractions such as quarters and eighths.

When introducing the activities, ask your students to explain what is meant by *area*. *Mathematics in the New Zealand Curriculum* (page 210) offers this definition: “the size (or measure) of a surface, expressed as a number of square units”. Explain that the challenge in today’s activity is to measure area using triangular units. A key concept that needs to be taught is that any measurement involves a comparison between two things, one of which is the standard. Usually the standard is found on a ruler (a centimetre), a set of scales (a gram or kilogram), a thermometer (a degree), or some other device that is sold specifically as a measuring device. But any standard can be used for purposes of informal comparisons, as in the statement “The new warehouse covers an area the size of 3 rugby fields.” That’s where the triangles in this activity fit in. They are not standard units of measurement, but we can still use them to make valid statements about the relative sizes of various shapes.

ACTIVITY ONE

The students should visualise how many triangles will fit into each of the shapes before drawing lines on their copy of the copymaster. It’s the visualising process that helps them to see that measurement is about making comparisons, not about following mathematical rules. Once students have visualised the answers, they can cut out the small triangle, if necessary, and use it to check their predictions.

Note that the answer for part e is more difficult to visualise because the triangle units won’t fit without “cutting”. Some students may need to actually cut and rearrange the triangles before they can see what the answer is.

ACTIVITY TWO

This activity is similar to the first in that it involves measuring a series of shapes, but this time, students work with a larger unit. If they find this difficult, discuss how the unit triangle could be divided into smaller parts that would more easily fit the different shapes. Ask “*What fraction of the large triangle is each of the smaller parts?*” (The small triangles are each $\frac{1}{4}$ of the larger unit, and the trapezium is $\frac{3}{4}$ of the larger unit.) Once the values of these parts of the unit triangle are known, students can, for example, imagine the shape in part a divided up into small triangles or trapeziums, like this:

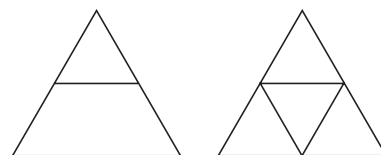

$$\frac{1}{4} + \frac{1}{4} + \frac{1}{4} + \frac{1}{4} + \frac{1}{4} + \frac{1}{4} + \frac{1}{4} = \frac{7}{4}, \text{ or } \frac{3}{4} + \frac{3}{4} + \frac{1}{4} = \frac{7}{4}.$$

If students have difficulty with the visualising or the sketching of lines on their copy of the copymaster, they could make some of the large unit triangles, cut them up, and move the parts around to check their predictions. They could also use the triangles from shape sets.

As for part e in **Activity One**, parts i and j are more difficult than the others because the triangle unit needs to be further split before its area can be compared with each outline.

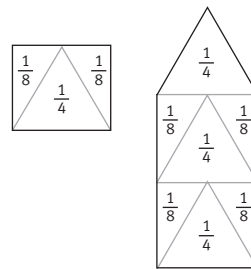

After the activity, encourage reflective thinking by asking questions such as:

- *What strategies did you find helpful?*
- *Which questions were the most difficult? What made them so?*
- *Why do you think the standard units for measurement of area are square (such as square centimetres, square metres, or square kilometres) rather than another shape?*
- *What suggestions would you give someone who was about to start this activity?*

Achievement Objective

- design and make a pattern which involves translation, reflection, or rotation (Geometry, level 3)

ACTIVITY

In this activity, students use symmetry to determine how to fold squares of paper and make a series of hole-punch patterns.

It's a good idea to pre-cut lots of squares before setting a group to work on this activity because they will get through quite a few! If you cut the squares 10 cm x 10 cm (memo cube size), you will get 6 from a recycled A4 sheet. This size is fine for most of the problems, although students may prefer to work with larger squares when trying to create the pattern in question 1g, which requires some tricky folding.

At first, let the students experiment and use trial and improvement to make each pattern. After they have made several, encourage them to look back at the holes and folds and see what they can observe. Ideas might include:

- "There is one hole in each folded section."
- "Each hole has at least one symmetrical partner."
- "There is a fold along each line of symmetry."
- "The lines through pairs of holes are at right angles (perpendicular) to the folds."

You could give the students a photocopy of the page in the student book and have them predict the folds by sketching the lines of symmetry. If they have problems with this, suggest that they draw dotted lines between each hole and its buddy and then draw the line that goes through the midpoint of the dotted line, at right angles to it. This is the *axis of symmetry* or *mirror line*. They can check their predictions by folding a paper square, using the lines they drew as guides, then punching a hole in it.

Ask "What strategies are you using to help you work out where the folds go?" Ideas might include:

- "I try to make each fold divide as many of the holes as I can."
- "I look for places where I can see that the hole patterns are symmetrical, and then I make a fold along the line of symmetry."

Encourage your students to notice and explain relationships and to make predictions:

- *If I fold a piece of paper in half, in half again, and in half again, and then punch a hole through all the layers, how many holes will I have? Can you convince me you're right without using the paper and punch?* (The answer is 8. See if the students realise that if they punch a hole through 8 layers, they will get 8 holes. So the number of holes tells them the number of layers.)
- *How many layers can you get by repeatedly folding an A4 sheet?* (64. But note that a typical hole punch will only go through about 16 layers.)

- If you fold the paper in half each time, what different numbers of layers can you get? Can you see a pattern in these numbers? (2, 4, 8, 16, 32, 64, 128, 256 ... The number of layers doubles each time. These numbers are the powers of 2: 2^1 , 2^2 , 2^3 , 2^4 , and so on.) What do the powers tell us? (The number of times the square has been folded in half.)
- Do all of Deepak's patterns have a number of holes that fits this pattern? (No, d and h have 12 holes each.)
- What might have happened if the pattern has 12 holes? (There are two possible reasons: 1. At some point, the paper has not been folded completely in half. If it is folded in half 3 times [giving 8 layers] and then just half of these layers are folded over for the final crease, there will be 12 layers. 2. The square could have been folded into thirds and then folded in half twice.)
- Is it possible to create a pattern with an odd number of holes? (Yes, by folding a single layer over at some stage after the initial fold or by leaving a single layer unfolded, like the triangular corner in this square with 7 holes.)

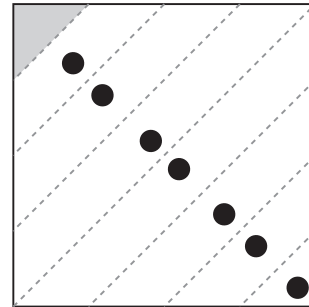

After the activity, encourage reflective thinking by asking questions such as:

- Which hole patterns were the hardest to make? What strategies did you use to help you?
- How did you use line (reflective, mirror) symmetry today?
- What tips would you give someone about to start this activity?

Achievement Objectives

- model and describe 3-dimensional objects illustrated by diagrams or pictures (Geometry, level 3)
- describe in words, rules for continuing number and spatial sequential patterns (Algebra, level 3)
- make up and use a rule to create a sequential pattern (Algebra, level 3)

AC
EA
AA
AM
AP

These three activities have been designed to help students learn to visualise 3-dimensional objects from their 2-dimensional representations and to make deductions about the hidden parts of the objects based on what they can see. Cantitowers (page 6) is a suitable activity to follow this one.

ACTIVITY

Before your students begin, you may need to clarify these points:

- The two cubes only show the number for the day, not the number for the month. So 1 and 2, in that order, represent the 12th day of any month.
- The cubes are fully interchangeable: the same cube doesn't need to stay in the ones or the tens position.

If students are having difficulty, scaffold the problem by asking:

- What numbers do you need to be able to make using the cubes? (1 to 31)
- Which digits would you need two of, one on each cube? (1 for 11, 2 for 22)
- How many faces are there on two cubes to put the digits on? (12)
- If you arrange the rest of the digits on the remaining faces after you have placed the two 1s and two 2s, are there any numbers that you can't make? (Students need to notice that 3 and 0 have to go on different cubes; the other digits can be arranged in any way. If they persist in putting the 3 and 0 on the same cube, challenge them to make the number 30 using their cubes.)

ACTIVITY TWO

The key to this problem is recognising that the picture shows three views of the same cube. This means that the red and yellow faces in the illustration at left are the same red and yellow faces in the illustration at right. If students rotate view 3 in their minds one quarter turn, they will give it the same orientation as view 1 and should be able to see that the orange face is on the bottom, opposite the blue.

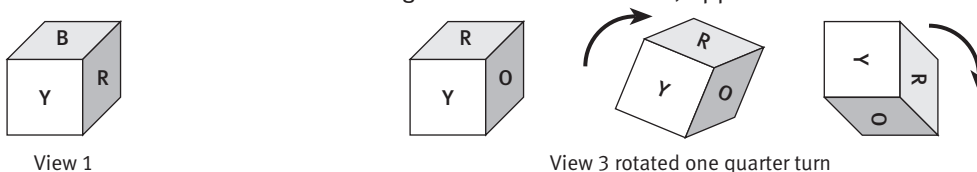

As a second step, students should imagine view 2 turned so that the blue face is on the top, as for view 1:

- *What face is now on the bottom?* (Orange)
- *If we now turn the cube around (blue still on the top) so that the green and purple faces are hidden, what colours will we see on the vertical faces?* (Yellow and red)
- *Which of the hidden faces must be opposite the red?* (Green) *And opposite the yellow face?* (Purple)

Many students find it difficult to visualise and rotate shapes like this in their minds. This doesn't mean that they shouldn't try. Let them then test their predictions by recreating the illustrations with cubes and coloured or labelled dots.

ACTIVITY THREE

Introduce and teach these mathematical words:

Face	a flat surface	Vertex	a corner, where 3 or more faces meet
Edge	where 2 faces meet	Vertices	plural of <i>vertex</i>

If students are having difficulty with question 1, ask them:

- *How many small cubes would you have if you were making Tahlia's cube?* (27)
- *This small cube (point to a corner cube) has all three of its faces painted. How many cubes are there like this one?*
(8: one at each vertex/corner)
- *Where are the cubes that have just one face painted? How many of these are there?* (6: one in the centre of each face)

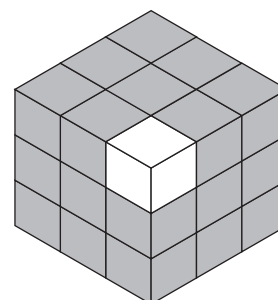

Have the students create a 3 x 3 x 3 cube using blocks or multilink cubes. They can use this to check their predictions.

In question 2, help your students to make links between the 3 x 3 x 3 cube and the larger ones by asking them to explain what is special about the location of each of the 4 kinds of small cube:

- Those with 3 painted faces are always on a vertex.
- Those with 2 painted faces are always along an edge.
- Those with 1 painted face are always in the centre of a face, not touching an edge.
- Those with no painted faces are always walled up inside the large cube.

Get the students to draw one face of the 4 x 4 x 4 and 5 x 5 x 5 cubes and to colour-code the different types of painted faces, for example:

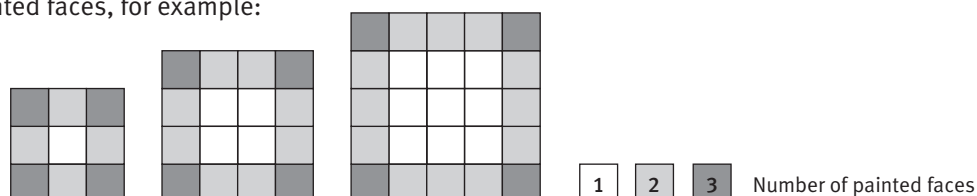

Ask the students what patterns they see developing. Key patterns are these:

- There are always 8 cubes with 3 painted faces because every cube has 8 vertices.
- The number of cubes with 2 painted faces is always a multiple of 12 because every cube has 12 edges.
- The number of cubes painted on 1 face is always a multiple of 6 because every cube has 6 faces.

Encourage the students to complete their tables with this level of detail so that the patterns become clear:

	Number of painted faces				Total
	1	2	3	none	
3 x 3 x 3 cube	$6 \times (1 \times 1) = 6$	$12 \times 1 = 12$	8	$1 \times 1 \times 1 = 1$	$3 \times 3 \times 3 = 27$
4 x 4 x 4 cube	$6 \times (2 \times 2) = 24$	$12 \times 2 = 24$	8	$2 \times 2 \times 2 = 8$	$4 \times 4 \times 4 = 64$
5 x 5 x 5 cube	$6 \times (3 \times 3) = 54$	$12 \times 3 = 36$	8	$3 \times 3 \times 3 = 27$	$5 \times 5 \times 5 = 125$

EXTENSION

Challenge your students to use the patterns they have discovered to predict the number of cubes of each type that there would be in a 6 x 6 x 6 cube or a 10 x 10 x 10 cube. (The numbers get quite large and difficult!)

	Number of painted faces				Total
	1	2	3	none	
6 x 6 x 6 cube	$6 \times (4 \times 4) = 96$	$12 \times 4 = 48$	8	$4 \times 4 \times 4 = 64$	$6 \times 6 \times 6 = 216$
10 x 10 x 10 cube	$6 \times (8 \times 8) = 384$	$12 \times 8 = 96$	8	$8 \times 8 \times 8 = 512$	$10 \times 10 \times 10 = 1000$

A Swiss mathematician, Euler (1707–1783), found a rule to describe the number of edges a 3-dimensional shape has:

$$f + v - 2 = e \text{ (number of faces + number of vertices - 2 = number of edges.)}$$

Test Euler's rule on a cube and some other 3-dimensional shapes.

After the students have completed the activities, ask these questions to promote reflective thinking:

- *Today we were using information we could see to work out hidden details. Can you give me an example of this?*
- *What did you find difficult about imagining the parts you couldn't see? What could you do about this?*

Pages 4–5

No Looking!

Achievement Objective

- describe the features of 2-dimensional and 3-dimensional objects, using the language of geometry (Geometry, level 3)

These activities give students opportunities to practise and refine giving precise descriptions of 2- and 3-dimensional objects. As the teacher, you will need to actively promote the use of geometrical language by introducing useful terms, encouraging students to use them, and asking questions that require students to reflect on how they could make their instructions clearer and more precise.

ACTIVITY ONE

The students are likely to learn most from this activity if you work through question 1 with the whole group. The following paragraphs describe one way of doing this:

Divide the group in half. One half will be instructors and the other half, model makers. The instructors will refer to the picture in the book but keep it hidden from the model makers. The model makers will share a box of multilink cubes and will keep their models hidden behind individual screens. (Picture books are ideal for this purpose.) Explain to everyone that the giving of instructions will be a co-operative effort but the model makers will work individually.

When you have given an overview of what will happen, ask the students what sort of information the model makers will need to know (for example, the number of cubes to be used, the colours required, the number of layers ...). Follow this discussion by introducing the list of mathematical words below, writing them on a chart. Explain that you want the instructors to use the words where appropriate.

Face	a flat surface
Edge	where 2 faces meet (as long as they are not parallel)
Vertex	a corner, where edges meet (plural: vertices)
Horizontal	flat, level, parallel to the floor
Vertical	upright, straight up and down, at right angles (perpendicular) to the floor

When everyone understands and is ready, invite the instructors to suggest suitable instructions. They should do this through you, in a co-ordinated fashion, so that you can write them on the whiteboard for discussion and evaluation when the models have been made. As each instruction is given and written up, the model makers try to follow it and construct their model.

When this phase is completed, ask the model makers to reveal their models and to compare them with the picture in the student book. If a model is not identical, ask the model maker to try to identify why. Then look back at the instructions as you recorded them and ask for suggestions for how they could be improved. Emphasise the value of geometrical words by underlining or ticking them each time they occur. Are there other words that should be on the list?

For question 2, after the students have had a chance to make their own model and instruct their classmate how to make it, ask:

- *What could your partner do to make their instructions clearer?*
- *Which geometrical words did you and your partner use?*
- *Did anyone manage to use all the words on our list?*
- *Did anyone use another geometrical word that we could add to our list?*

The models in question 2 can be as complex as you or your students want them to be. The illustration shows one made with 12 multilink cubes.

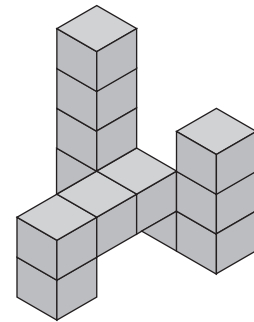

ACTIVITY TWO

Some of the diagrams on the copymasters will prove quite difficult to describe, and the students will find that the task is much easier if they have the geometrical words they need. Talk about this with your group because they may otherwise feel that mathematical terms are just complicated ways of talking about simple things.

There are numerous geometrical words that could be used in this activity, but it's best to concentrate on those that are likely to be needed. Each word on the following list will be helpful when describing at least one of the figures on the copymasters. Add the words to your list and display it in a prominent place so that the students can refer to it while they are doing the activity. Alternatively, photocopy a list for each student and get them to tick each word as they use it.

If you make up a puzzle that involves matching the terms and their definitions, this will give you an opportunity to clear up areas of linguistic confusion.

Congruent	having the same shape and size
Adjacent	adjoining, next to (each other)
Apex	the highest point of a shape or figure
Midpoint	the point that is the same distance from each end
Intersect	cut across each other
Perpendicular to	at right angles to
Parallel (to)	having the same direction (as)

Equidistant	at an equal distance from
Diagonal	a line that joins 2 non-adjacent vertices
Diameter	a straight line that goes from one side of a circle to the other, passing through the centre
Equilateral	having all sides the same length
Isosceles triangle	a triangle with 2 equal sides and 2 equal angles
Polygon	a closed (enclosed) 2-dimensional (flat) shape bounded by 3 or more straight lines
Quadrilateral	a 4-sided polygon
Trapezium	a quadrilateral with 1 pair of parallel sides
Kite	a quadrilateral with 2 pairs of equal and adjacent sides
Pentagon	a 5-sided polygon
Symmetrical	able to be reflected or folded onto itself
Interior angle	an angle inside a shape
Right angle	an angle measuring 90 degrees
Component	a part of the whole

Again, it is a good idea to involve the whole group in an introductory task before letting them get on with it. This gives you another opportunity to model and reinforce what is wanted and is likely to lead to the best learning outcomes. Those who made the models in the first demonstration should now be the instructors. Draw this figure on a sheet of paper and hold it up so that only the instructors can see it. The other half of the group will need pencils and paper and will draw it behind individual screens (books).

Before they start, ask the students what sort of information those doing the drawing will need to be given. (For example: which cell on the blank grid they are to draw the figure in, what the finished picture looks like, what the component shapes are, how big the parts are relative to each other, where each shape is positioned ...) Ask the students to suggest how they could make sure that the other person draws the parts of the figure the right size and positioned in the right part of the square. Suggestions might include:

- “You could divide the big square into smaller squares (see the dotted lines).”
- “You could estimate in centimetres or millimetres the size of each component shape and its distance from the edge of the square.”
- “You could describe what lines up with what.”

As instructions are given, record them so that the students can evaluate and improve on them once the figure is revealed for all to see, as with the first activity. The students should now be ready to do question 1 in pairs without further guidance.

Question 1 may take all the time you can allocate for this maths session. If this is the case, you could use question 2 as a follow-up task to be done another day.

After the activities, encourage reflective thinking by asking these questions:

- *What made it easier to recreate the other person’s object or drawing? Which words or phrases did you find useful?*
- *What made it difficult? What could you do to overcome these difficulties?*
- *Which geometrical terms did you use? (You could use your vocabulary chart as a checklist.)*
- *What tips would you give to someone else about to do this activity?*

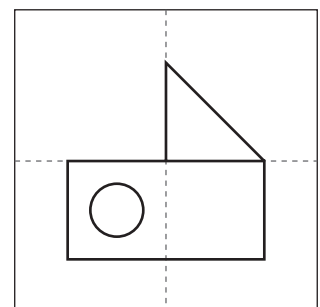
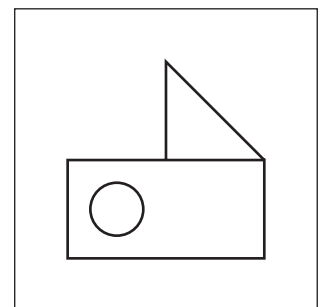

Achievement Objectives

- model and describe 3-dimensional objects illustrated by diagrams or pictures (Geometry, level 3)
- draw pictures of simple 3-dimensional objects (Geometry, level 3)
- make a model of a solid object from diagrams which show the views from the top, front, side, and back (Geometry, level 4)
- draw diagrams of solid objects made from cubes (Geometry, level 4)

This activity gives students opportunities to visualise and build 3-dimensional models based on 2-dimensional diagrams of side views and then to create and draw some of their own. Some will need very little help with this; others will find it surprisingly difficult. You should be prepared to guide the latter group through the decoding process. These notes suggest how you might do this.

ACTIVITY

Introduce question 1 by looking together at the diagrams of the first model. Help the students decode the information by asking questions such as:

- *What clues do these four diagrams give us about Ainslie’s first model?* (Possible ideas are: there are 3 layers; there are 2 blocks on the first and second layers, but only 1 block on the top layer; it’s a long, thin model; 1 side goes up in steps ...)
- *How many blocks are in the model altogether?* (5. In this activity, they’re told the number, but this won’t always be the case.)
- *Why does it look like there are only 3 blocks in the two side views?* (2 blocks are hidden behind the 3 in front.)

Draw a diagram like this on the whiteboard and say “This is a picture of an 8-stud block, but only 2 studs are shown. Why?” (Because we’re looking at the end of the block.)

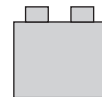

To help your students recognise the significance of the studs shown in the 2-D diagrams, draw diagrams on the whiteboard of these two views of a 2-block model and ask:

- *What is the difference between these two views?* (The left view shows the joining studs on the bottom block.)
- *How does this difference affect the 3-D model?*
- *Using just 2 blocks, can you show me what the model might look like?*

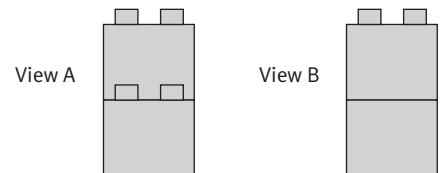

Make sure the students recognise that the bottom block in view A must have at least 2 of its studs protruding in front of the top block but that we can’t tell from this view exactly how many. Here are the possibilities for 2 joined blocks:

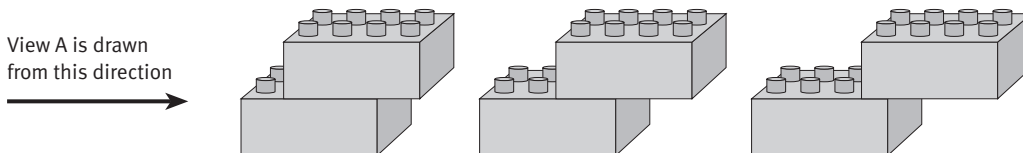

All the studs on the bottom block in model B are hidden from view. This means that they are either tucked up inside the top block or shielded by it. If we had only the one view, the diagram could represent 1 block sitting squarely on another, or a pair of receding steps. We can’t tell from this view if there is a step, and if there is one, how big it is. Here are the possibilities for 2 joined blocks:

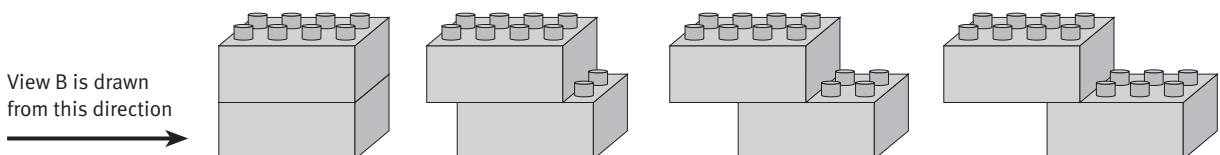

To explore how blocks that are the same distance or different distances from the viewer can appear the same, have the students make the two 3-block models below and then show you the sides of their models that are represented by the 2-D diagram on the right. (Draw it on the whiteboard.) Discuss how the 2-D view doesn't show whether a block on the bottom layer is further forward or back from its neighbour and warn them to be aware of this when they are making the models in the activity. It is only by checking a model against all four views (front, back, and sides) that we can be sure that it is correct.

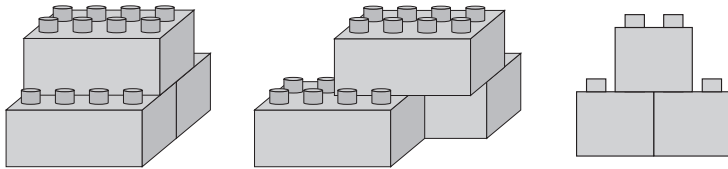

Now have the students make Ainslie's first model and compare it with the given views and a classmate's model. If they have difficulties, suggest that they start with the top or bottom layer and work systematically, one layer at a time, turning their model and checking all four views each time they make a change.

These activities will show which students are persevering in the face of difficulties. Show that you value this quality and encourage them to keep trying, having a go at each of the models in turn and checking them carefully against all four views before comparing them with a classmate's. If their model is different from their classmate's model, get them to look again at the four views and find out what is wrong.

When talking about the models, use these terms and encourage your students to do the same:

Face	a flat surface
Edge	where 2 faces meet (as long as they are not parallel)
Vertex	a corner, where edges meet (plural: vertices)

Question 2 calls for students to draw the front, back, and side views of three of their own models on square dot paper. This is related to but different from the skill of interpreting drawings done by others, and some may find the task difficult. If this is so, ask them to make and draw the 2-block models illustrated here before attempting their own more complex 5-block models.

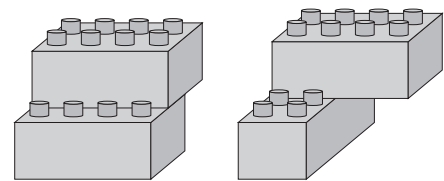

If students have difficulties with question 3, remind them that there are 5 blocks in each model and ask them:

- *How many blocks are in the top layer of model a?*
- *How do you know?* (There must only be 1 block, because two views show 4 studs [the long sides] and the other two show 2 studs [the short sides].)
- *How many blocks are in the bottom layer of model a?*
- *How do you know?* (It must be made up of more than 1 block because the front and back views show 6 studs.)

Encourage lots of trial and checking, emphasising the importance of perseverance and being systematic.

After the activity, ask questions such as these to encourage reflective thinking:

- *If you were teaching another person how to understand these 2-D diagrams, what would it be important to tell them?*
- *Which parts of this activity did you find difficult?*
- *What did you do to solve the problems that you met?*

Achievement Objective

- model and describe 3-dimensional objects illustrated by diagrams or pictures (Geometry, level 3)

ACTIVITY

In this activity, students visualise whether nets can be cut and folded to make open boxes and then check their predictions with the help of the copymaster.

To introduce the activity, ask the students how many faces an open box will have (5). Give each of them a copy of the student book or a photocopy of the copymaster. (If possible, enlarge the copymaster to A3 size for ease of cutting and folding.) Ask them to independently predict which of the nets will make open boxes and then to explain to a classmate why the others won't.

Introduce and promote the use of these words:

Net	a flat (2-D) pattern that can be cut and folded to form the surface of a solid (3-D) shape
Face	a flat surface
Edge	where 2 faces meet (as long as they are not parallel)
Vertex	a corner, where edges meet (plural: vertices)

Ask questions such as:

- *How many faces are there on Kayleigh's boxes?* (5, not including the invisible "open" face where the lid of the box belongs)
- *How many vertices are there on her boxes?* (8)
- *How many edges are there on her boxes?* (12)
- *At how many vertices on Kayleigh's open boxes will 3 faces meet?* (4 – the bottom 4 corners of each box)
2 faces? (4 – the top 4 corners of each box)

Following this discussion, have the students check their predictions by cutting out the nets and folding them. When they have done this, ask them what clues they can find in the nets for **b**, **f**, and **h** that show that they won't make open boxes. Ideas might include:

- "b is a strip. The only two edges that can be joined are the 2 end edges, and if we join them, we will get a 5-sided loop, not a box."
- "f has the right number of faces and folds but when folded, 2 faces will overlap, meaning that the 'box' would have 2 bottoms and be missing 1 side."
- "h can't be an open box because it has 5 folds instead of 4."

Note that while it is possible to draw up some rules and tests that can help us decide whether a net will make a box, the focus should be on teaching students the spatial reasoning skills that will prove useful in a much wider range of situations.

EXTENSION

Two-dimensional shapes made from 5 squares joined together are often known as pentominoes, and they form the basis of many puzzles. There are only 12 different pentominoes, and 11 of them are illustrated in the activity. Challenge your students to find the remaining one (pictured at right). Note that a pentomino and its mirror image are considered to be one and the same piece.

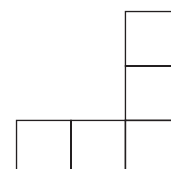

Challenge your students to fit all 12 pentomino pieces together to make (i) a rectangle and (ii) the net of a cube.

Hexominoes are similar to pentominoes but are made by joining 6 squares instead of 5. Draw this hexomino on the whiteboard and ask “*Could this hexomino be folded to make a box with a lid? Describe to your partner why you think this.*”

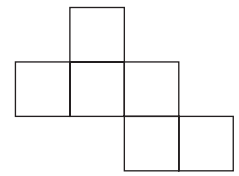

Challenge your students to see how many hexominoes they can find. (There are 35.) They will find that it helps to draw them systematically and to cut them out and rotate and flip them to make sure that they haven’t doubled up on any. Get them to mark the hexominoes that could be folded to make a box with a lid.

If students enter *pentomino* or *polyomino* into an Internet search engine, they will find many interesting puzzles to try. They will find that doing puzzles of this kind improves their spatial reasoning skills (at the same time as it tests their perseverance!).

Achievement Objectives

- describe patterns in terms of reflection and rotational symmetry, and translations (Geometry, level 3)
- devise and use problem-solving strategies to explore situations mathematically (Mathematical Processes, problem solving, levels 2–4)

ACTIVITY

In this activity, students are challenged to solve two puzzles involving chessboards. They do not need to know how to play chess to do the problems, but they will need plenty of perseverance! Don’t be put off giving them to your link students; they proved very popular when trialled, and students persisted even when their teachers had given up! If they can’t find the solutions in the time allocated, let them come back to them over several days if necessary.

PUZZLE ONE

Introduce the problem and clarify what it requires by asking:

- *How many squares are there on the whole chessboard?* (64)
- *So how many will be in each piece when you cut it up into four congruent parts?* (16)
- *Why can’t you just cut it into four 4 x 4 squares?* (Because each piece has to have a knight sitting on it.)

Each student will need more than one copy of the copymaster, especially if they are to cut them up. Alternatively they could draw their own 8 x 8 “chessboards” on square grid paper and experiment with these. They should try and use pencil for much of their thinking (rather than scissors): it is much easier to erase a couple of lines than to make up another grid.

The key to this puzzle is rotational symmetry. A rotation is when an object is turned about a fixed point, known as the centre (of rotation). A design is said to have rotational symmetry if, when turned about a point, it fits onto its original position exactly. For example, this design would fit onto its original position 4 times as it is rotated through one full turn about the centre. We say therefore that the design has rotational symmetry of order 4.

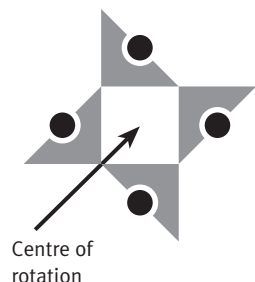

If students are unable to get anywhere with the puzzle, try posing a similar but simpler problem: “*Can you cut this shape into 2 congruent pieces so that each piece has a knight on it?*”

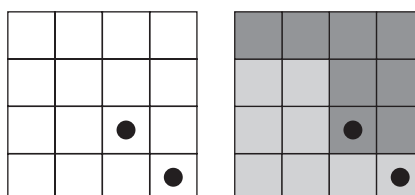

You could also prompt them to think in terms of rotational symmetry by asking them “How could you arrange these 4 congruent pieces (see below) so that they make a complete 4 x 4 square? The first piece has already been put in position.”



Tell your students that the solution to Amy’s grandmother’s puzzle has rotational symmetry and that the centre of rotation is in the centre of the chessboard. This information, combined with the partly completed piece shown in the illustration in the student book, should be enough to set them on the right path. If a further clue is needed, show how the board can be divided into four concentric squares, each with a knight on it, as in the picture at right. This division suggests (correctly) that the four congruent pieces will each consist of a quarter of each of the four concentric squares.

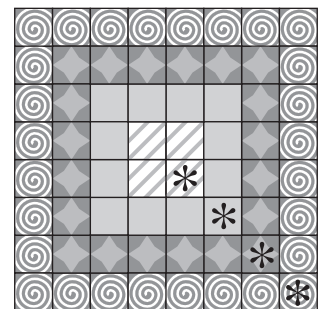

PUZZLE TWO

When students are trying to solve this puzzle, encourage them to use the mathematical words *horizontal*, *vertical*, and *diagonal*. Use them yourself in questions and discussion.

Unlike **Puzzle One**, which requires an element of inspiration, students can solve **Puzzle Two** by doggedly moving queens (counters) around until they find a configuration that works. Once the students understand what is required, leave them to try and work it out themselves. If they think they have solved the puzzle, get them to check each diagonal; it is easy to find a “solution” that looks right when it is not. There are 12 distinct solutions to the puzzle (ones that are not just reflections or rotations of another). Once students have found one, encourage them to find another.

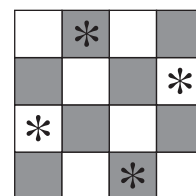

If they are getting nowhere and appear inclined to give up, take them back to a simpler problem: place 4 queens on a 4 x 4 board so that all are safe. The solution is in the diagram on the right.

Talk your students through the simpler problem and then transfer them to the 8 x 8 board. Those who are familiar with chess may realise that if 2 queens are separated by a knight’s L-shaped path (2 steps followed by a 90° turn and 1 more step, or vice versa), each queen is safe from the other.

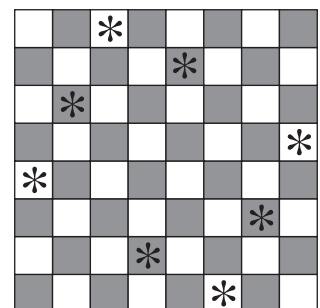

Of all the 12 solutions to the puzzle, only the one in this diagram shows symmetry. You may like to show it to your students and discuss its special features.

EXTENSION

Sudoku puzzles have certain similarities to the queens puzzle. They use a 9 x 9 grid (not 8 x 8), and the digits 1 to 9 (not queens) have to be placed in every cell in such a way that no digit is repeated in a row or a column. In the case of sudoku, diagonals are irrelevant, but the 9 x 9 grid is subdivided into 3 x 3 subgrids and each digit is allowed to appear only once in each of these small grids. A game board comes with some of the digits already placed. This placement is always symmetrical: rotational and/or reflective. The aim of the game is to complete the board.

Sudoku games don’t require any mathematical knowledge (apart from the ability to recognise the digits 1–9), but playing them helps to develop spatial reasoning, logic, and perseverance. Many teachers have found them an excellent classroom activity. You can find Sudoku puzzles in most daily newspapers or get them from www.nzherald.co.nz/sudoku or paperbacks dedicated to them. They are graded from easy to extremely difficult. This makes them even more ideal for the classroom because different students can work at different levels. But if you plan to introduce them to your students, make sure that you start with the easiest grade. Be warned that these puzzles can be very addictive!

Achievement Objectives

- demonstrate knowledge of the basic units of length, mass, area, volume (capacity), and temperature by making reasonable estimates (Measurement, level 3)
- perform measuring tasks, using a range of units and scales (Measurement, level 3)
- read and construct a variety of scales, timetables, and charts (Measurement, level 4)

ACTIVITY ONE

To introduce the activity and to help the students clarify what is meant by each of the measures in Jason’s list, find five objects of your own and ask the students: “If I were going to put these in order from least to greatest according to their mass (weight), which object would I put at the least end? Which object would I put at the greatest end?”

By doing this, you will see which students need the term *mass* clarified. Repeat the questions for surface area, length, volume, and circumference.

The following words play an important role in this activity. Teach them, using examples. List and display them on a chart. Encourage your students to use them:

Mass	the amount of matter in an object (measured in grams, kilograms, tonnes ...). The term <i>weight</i> is often used, imprecisely, instead of mass.
Weight	the force of gravity pulling on an object’s mass makes its weight. (In science, weight is a force and is measured in newtons rather than kilograms.)
Surface area	the area of the outside of a solid (measured in square units, such as square centimetres)
Volume and capacity	are essentially different ways of looking at the same thing. The volume of an object or substance is the amount of 3-dimensional space it occupies, measured in units such as cubic centimetres (cm ³) or cubic metres (m ³). Capacity is the amount a container can hold, measured in units such as cm ³ , m ³ , millilitres (mL), or litres (L). In any given context, one of these two words is likely to be more appropriate than the other. Where the emphasis is on the size of an object, we would normally talk about its volume; where the emphasis is on how much the object can contain, we would normally refer to its capacity. <i>Capacity</i> is not used when referring to solid objects.
Circumference	the boundary of a geometric figure, especially a circle; the length of that boundary

After the students have ordered their own items and shared the guessing role, ask:

- *What strategies did you use to put the objects in order?*
- *Which objects and measures did you find hard to order? Why?*
- *Do you have an object that was at the greatest end of the order for one of the measures but at the least end for another measure? Which one?*

ACTIVITY TWO

If your students find it difficult to think of other measures, treat question 1a as a task for the whole group and write all ideas on the board. Ideas could include: height, number of visible words, holeyness, multicolouredness, number of component parts, redness, cost (monetary value), bendiness. Once the brainstorming has run its course, get the group to edit out any measures that are likely to be unusable. When the students go off in pairs to complete question 1, they should agree on the list of measures that they will use and write it down. It doesn’t need to contain every suggested measure; each pair could limit their list to five or six measures.

Question 2 asks students to try to develop scales for their different measures. You may need to clarify for them the essential features of a scale:

- It consists of an ordered series of gradations (steps) or benchmarks (descriptors).
- These steps have equal intervals (gaps) between them.
- Its purpose is to measure something.

Measurements are made by comparing the attribute (quality or characteristic) being measured against the steps or benchmarks on the scale.

Students may not have all the words they need for the descriptors on their scales. If this is the case, they may find a thesaurus helpful.

A possible approach to question 3 is to divide the students into groups of 3–4 and give each group a pile of memo cube squares or stickies. Give the groups a few minutes to write down as many different standard units as they can think of, one per square or sticky. The next task is to classify the units according to the attribute that each one measures. The final task is to sort each class of units into their correct order from least to greatest.

Give the students time to look at, compare, and talk about the results of their brainstorming. Then try a “spying mission”: half the students from each group walk around looking at the work done by other groups, talking to those who have stayed put, and making notes about things they want to incorporate into their own work. Then give them time to finalise details and to stick the ordered lists of units, in their categories, onto large sheets of paper for display.

EXTENSION

This activity is an effective generator of questions for independent investigation; students can record these questions on their charts as they arise. You could generate further questions for investigation by asking students what units are used to measure things like electricity, angles, temperature, force, speed, light, pressure, sound, fuel consumption, and so on. (See the Answers.)

Suggest to students that they enter “*metric measurement*” + *history* in an Internet search engine. By exploring some of the sites that are listed, they will be able to find out about how the metric system of measurement was adopted following the French Revolution. Nearly all countries now use this system, which was originally based on the Earth’s size and other physical attributes and designed so that the different units related sensibly to each other. Using it, calculations are so much easier than they were with historical units. Students could also discover that the USA still uses many non-metric units (such as ounce, gallon, and mile) and the reasons for this.

Pages 12–13 Judgment Calls

Achievement Objectives

- carry out practical measuring tasks, using appropriate metric units for length, mass, and capacity (Measurement, level 2)
- demonstrate knowledge of the basic units of length, mass, area, volume (capacity), and temperature by making reasonable estimates (Measurement, level 3)
- perform measuring tasks, using a range of units and scales (Measurement, level 3)

This activity gives students opportunities to estimate and measure time, length, and weight (mass). It is designed to help them develop mental benchmarks for measures such as a minute, a metre, or a kilogram. Such benchmarks are a great help when making estimates. Using a benchmark, we can work from the known to the unknown with a good level of confidence instead of relying on pure guesswork. Here is an example of reasoning from a benchmark: “I know that it’s a metre up to my armpit, and the width of this table is about three-quarters of that length, so it must be about 75 cm wide.”

Your students are likely to be confused about the difference between *estimate* and *guess* because the two words are often used interchangeably as in “guess/estimate the number of jellybeans in the jar”. But when we use the word in a maths context, *estimate* always involves making a calculation of some kind, based on benchmarks/experience and simplified numbers. The difference can be seen in this example: “I’m thinking of a number between 1 and 9. Guess my number.” No kind of calculation is going to help in a situation like this, so “guess” is the right word. “Guess the height of that building” is an invitation to pluck a number out of the air; “Estimate the height of that building” is a challenge to do some calculating.

Estimate	a simple calculation or a judgment that is close enough to an exact result to be useful
-----------------	---

ACTIVITY ONE

After the students doing question 1 have tried estimating 1 minute, talk about the techniques used by group members to keep track of the time. Some will have relied totally on “feeling” the passage of time. Others may have learned techniques such as counting to themselves: “1 crocodile, 2 crocodiles, 3 crocodiles ...” or moving their finger up and down their forearm 60 times. Ask “*What technique gave the best result? Would it give the same result another time?*”

After the discussion, let everyone make a second attempt at judging 1 minute. Students can use the same technique as before or try one that someone else has suggested. You could let them have several more attempts and then get them to graph their times so that they can be easily compared. Ask “*Are your estimates getting more accurate with practice?*”

Question 2 involves a pendulum. The frequency of a pendulum is determined mostly by the length of the string. The mass of the weight and the angle at which it is released have little or no effect. Allow your students to experiment with the variables as they try to get their pendulum to swing at the right rate. Suggest that they alter just one variable at a time so that the effect of the change can be observed.

Students may want to know why it is that their pendulum always slows down and comes to a stop. The main reason is air resistance.

ACTIVITY TWO

Questions 1 and 2 are part prediction and part benchmarking. If students can find and remember a place on their body that is 1 metre above the ground, they can use this as a reference (until they grow!) when making estimates.

Encourage your students to try other measurements, such as their outstretched handspan, elbow to wrist, elbow to fingertip, width of thumb, length of a single pace, and so on. If they can discover a couple that are convenient and easy to remember (for example, a student might find that their handspan is 20 cm), they should memorise these and use them when estimating. They will also be useful when it comes to recognising unlikely or foolish answers to calculations.

The first two questions in **Activity Two** involve small lengths. Question 3 is about bigger lengths.

Students should use the information from their first trundle wheel measurements to help with subsequent estimates; for example, “I know that the length of the classroom is 12 m. The playground is about three classrooms long, so I estimate that it must be about 36 m in length.” Again, it is a good idea if students can develop some benchmarks for use when estimating longer distances: measure and talk about what 5 and 10 m look like, and make use of measured distances such as the local swimming pool (25 m), the sprint track (100 m), and the relay track (400 m). Some even longer benchmarks are handy: “*Use a map to work out points that are a kilometre from school, how far it is from our school to our town or city centre, and the distance from our town to the next nearest town.*”

ACTIVITY THREE

This activity will help students establish benchmarks for mass by identifying objects of particular masses and will give them practice at estimating mass by comparing objects with a known mass.

ACTIVITY FOUR

This is a useful question to promote reflective thinking and is also a valuable assessment opportunity. Get each student to write their three things on a coloured piece of paper and then put these up as a display. This display will be useful for reference and reinforcement as you come back to it over the following days.

Challenge students to memorise and use their benchmarks to make estimates during the week and have them report back to the group on their experiences next session.

What's the Connection?

Achievement Objectives

- demonstrate knowledge of the basic units of length, mass, area, volume (capacity), and temperature by making reasonable estimates (Measurement, level 3)
- perform measuring tasks, using a range of units and scales (Measurement, level 3)

AC
EA
AA
AM
AP

The purpose of this activity is to develop students' understanding of the relationships between standard units in the metric system by making connections between the measures for mass and volume. Specifically, they should understand that 1 L of water has a mass of 1 kg and occupies the same volume as a cube measuring 10 x 10 x 10 cm.

This is definitely an outside or wet area activity!

ACTIVITY

Question 1 is an entirely practical activity and will require some prior organisation. The students need to work in pairs or small groups. It is unlikely that you will be able to collect enough measuring jugs and kitchen scales for an entire class to do this activity simultaneously. For this reason, you may want to have other groups working on one or more of the other measurement-related activities in this book (for example, Secret Scales, Judgment Calls, or Eyeball Estimates).

The students need to carry out the task with a clear understanding that they are looking for the answer to the question posed by part c. With care and fairly accurate measuring equipment (kitchen scales and a graduated jug), they should be able to discover the "handy connection" for themselves.

The following words are relevant and important. List and display them on a chart and encourage your students to use them:

Mass	the amount of matter in an object (measured in grams, kilograms, tonnes ...). The term <i>weight</i> is often used, imprecisely, instead of mass.
Weight	the force of gravity pulling on an object's mass makes its weight. (In science, weight is a force and is measured in newtons rather than kilograms.)
Volume	the 3-dimensional space occupied by an object (measured in cubic units, such as cubic centimetres or cubic metres)
Capacity	the interior volume of a container, how much fits inside (liquid capacity is measured in units such as litres and millilitres)
Displacement	what happens when something is moved from its normal location to make way for something else. By measuring the amount of water an object displaces, we can determine its volume.

For a fuller discussion of the words *volume* and *capacity*, see the notes for Secret Scales, page 22. Students also need to know these units for volume, mass, and length:

Volume	1 litre (L) = 1 000 millilitres (mL) 1 millilitre = 1 thousandth of a litre
Mass	1 kilogram (kg) = 1 000 grams (g) 1 gram = 1 thousandth of a kilogram
Length	1 metre (m) = 100 centimetres (cm) or 1 000 millimetres (mm) 1 centimetre (cm) = 1 hundredth of a metre 1 millimetre = 1 thousandth of a metre

In question 2, the idea is to make use of the connection established in question 1. Compared with the mass of the water in them, the mass of the plastic containers is likely to be negligible, and students should be able to predict the total mass with a fair degree of accuracy. The question also makes it clear that volume and capacity have no shape: the amount of water that would fill a 10 cm cube is the same as fills a 1 L drink bottle.

When doing question 3, students need to realise that there are one thousand 10 cm cubes in a cubic metre if they are to use the “handy connection” to work out how much water would fill such a big container and what it would weigh.

If students need help with this, you could use a 1 000 cm³ cube with the divisions marked and get them to pretend that each of the small cubes is a 10 cm cube. Alternatively, you could draw a diagram like the one shown and ask them to construct a reduced-size version of the solid using multilink cubes. After a short time, they will run out of patience and/or multilink cubes but should be able to visualise the finished solid and the number of cubes that would be needed to make it.

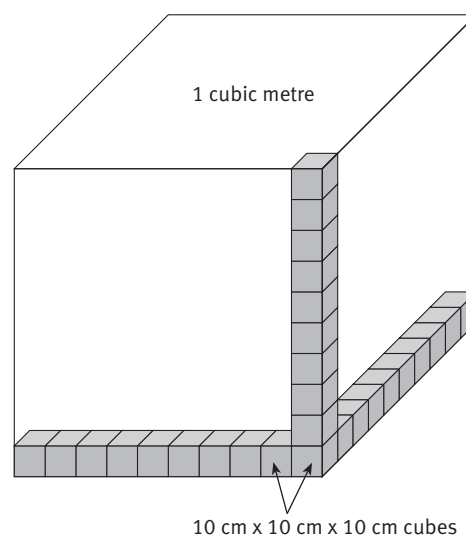

EXTENSIONS

Ask your students whether they think that the connection they have discovered in this activity should be true for liquids other than water.

Strictly speaking, 1 L of water has a mass of 1 kg only if the water is pure, the temperature 4°C, and the pressure 760 mm of mercury. In everyday situations, these factors can be ignored because their effect is minimal.

To help your students see that this connection is not necessarily true for other liquids, ask them to predict what would happen if they put oil and water together in a glass and then get them to find out by pouring a small amount of cooking oil into a glass that is partly filled with water. Ask “*If 1 L of water has a mass of 1 kg, how much would you expect the mass of 1 L of oil to be?*” (Less than a kilogram – it floats and is therefore lighter than water.) Repeat the experiment with golden syrup, which is heavier than water. Ask “*If 1 L of water has a mass of 1 kg, what would you expect the mass of 1 L of golden syrup to be?*” (More than a kilogram.)

So, no: the connection is not true for other liquids. But most will weigh quite close to 1 kg, so this is a guide worth remembering.

The “handy” kilogram–litre connection is not a happy accident. All measuring systems have been constructed by humans, and this connection was deliberately made by the people who designed the metric system and set it in place over 200 years ago. You could challenge interested students to find out more; there are a number of very informative sites on the Internet.

There are a number of picture books that explore measurement through displacement. These include *Mr Archimedes' Bath* (Pamela Allen, Harper Collins, 1998), *Who Sank the Boat?* (Pamela Allen, Penguin Australia, 1990), and *How to Weigh an Elephant* (Bob Barner, Bantam Doubleday Dell, 1995). See also *Floating and Sinking* (Building Science Concepts, Book 37) and *Understanding Buoyancy* (Building Science Concepts, Book 38).

At the conclusion of this activity, ask:

- *What did you learn today?*
- *What was “handy” about the connection?*
- *What difficulties did you have? How did you overcome them?*

Achievement Objective

- demonstrate knowledge of the basic units of length, mass, area, volume (capacity), and temperature by making reasonable estimates (Measurement, level 3)

AC
EA
AA
AM
AP

Estimating is an important skill that can be used in many real-life situations, and it's one that improves rapidly with practice. This activity gives students opportunities to develop their estimating skills in a variety of different scenarios.

It is useful to recognise three kinds of estimation processes (and skills):

1. Measurement. This kind involves a measurement (continuous) variable and requires the use of suitable benchmarks. See Judgment Calls for examples.
2. Computational. This kind involves simplifying numbers in an appropriate way to reduce the complexity of a calculation, often to the point where it can be done mentally.
3. Numerosity. This kind involves estimating the number of items in a given situation (always a discrete or whole number variable). This is done by benchmarking and often goes hand in hand with computational estimation. Examples include the number of people in a crowd, coins in a stack, or fish in an aquarium.

When tackling the challenges in Eyeball Estimates, students should try and distinguish which of the three kinds of estimation are involved.

ACTIVITY

Use question 1 as the subject for class discussion or small-group discussion followed by a report back and class discussion. It is important that students understand that *estimate* and *guess* are not the same thing (see the introduction to Judgment Calls, pages 23–24) and why they need to know how to estimate.

Estimating is the process of coming up with an approximate answer that is accurate enough for our purpose. Estimates are useful:

- when we don't need or want an exact answer (for example, how far it is to the dairy)
- when, for some practical reason, it is difficult or impossible to get exact numbers or measurements (for example, the number of people in a crowd)
- when we don't have a measuring device with us (for example, the dimensions of the bedroom we will be moving into in our new house)
- when we have measured or calculated something and want to make sure that our result is sensible.

After looking at how Lakisoe and Sara estimated the number of people that would fit into their school hall, ask the students to suggest situations where they have used estimation or observed others using estimation. Ask them why it was more appropriate or useful to estimate in those situations than to make an accurate measurement or do an exact calculation.

Question 2 gives students a number of scenarios and asks them to choose three. This means that they can choose ones that interest them and have an appropriate level of difficulty. They are told to write their methods down; this is part of the learning process, and the written notes are needed for the discussion that takes place in question 3.

In each case, the estimate must be based on some real information with numbers in it; otherwise it is a guess, not an estimate. This information may be a known fact (a benchmark), or it may need to be gathered:

- If a student gets a classmate (who says their height is 156 cm) to stand by a tall tree and uses their eye to judge that the tree is 8 times the person's height, they can then estimate that the height of the tree is $1.5 \times 8 = 12$ m. In this case, the real information was a known fact (the height of the classmate).
- If a student times a classmate bouncing a ball and finds that it takes 42 seconds (about $\frac{3}{4}$ of a minute) to bounce it 50 times, they can then estimate that it will take about $\frac{3}{4} \times 40 = 30$ minutes to bounce it 2 000 times ($50 \times 40 = 2\ 000$). In this case, the real information had to be gathered (the time taken for 50 bounces).

You will need to decide how much help you should give your students before sending them off to make their estimates. One approach is to put them into pairs, give them time to decide which of the estimates they are going to work on, and get them to write down the methods they plan to use. They could then combine with another pair (who may have chosen different challenges) and critique each other's strategies. Or you could get the whole group together to say which challenges they are taking on and to share plans before putting them into action.

Your students may struggle with some of the calculations if they aren't allowed to use a calculator, but wherever possible, they should try to cope without. They won't see the point of simplifying the numbers (for a computational estimate) if they can equally easily work out the exact result. Encourage them to use a pencil and paper to jot down intermediate working stages.

Questions 3 and 4 are for follow-up. Question 3 should highlight the fact that there is normally a variety of different ways of arriving at an estimate and that there is no one "correct" estimate for any given situation. You will need to make it clear that one estimate may be better than another (because it gives a better approximation of the actual measurement or number) but that both may be completely acceptable estimates. This is not the same as saying that any estimate is OK. (10 is not an acceptable estimate for 27!)

Try these questions to promote reflective thinking:

- *Can you explain the difference between estimating and guessing?*
- *Give an example of where you would estimate something instead of measuring it. Why would estimating be more appropriate or better in this situation than measuring?*
- *Why might different pairs have come up with different estimates for the same challenge?*
- *Can you tell which of two estimates is closer to the truth without actually doing the measuring?*
- *What could help you improve your estimating skills?*

Achievement Objectives**Mathematics**

- write and solve problems which involve whole numbers and decimals and which require a choice of one or more of the four arithmetic operations (Number, level 3)
- demonstrate knowledge of the basic units of length, mass, area, volume (capacity), and temperature by making reasonable estimates (Measurement, level 3)

Social Studies

Students will demonstrate knowledge and understandings of:

- how people participate in the production process (Resources and Economic Activities, level 2)
- how and why people manage resources (Resources and Economic Activities, level 3)

AC
EA
AA
AM
AP

ACTIVITY

This activity is based around olive growing and processing. Students are given information and a series of deductions based on that information. They have to read and interpret the information for themselves and use it to check each deduction to see if it is correct. Reasoning must be given. Along the way, students work with rates, a variety of different units, and some fairly large numbers. The activity provides a great context for using estimation skills to check the reasonableness of results. Students at levels 2–3 will need to use a calculator for some of the calculations. Advanced Multiplicative thinkers (Number Framework, stage 7) should take the opportunity to practice their multiplicative strategies.

The important units used in the activity are listed in a panel in the students' book. Students need a reasonable understanding of these before they start. As long as they have this, their understanding will be strengthened as they work through the statements a–k. It is particularly important that they understand that $1 \text{ L} = 1\,000 \text{ mL}$.

Some students may not have tasted olives or know that they grow on trees and can be pressed to make oil. So you could introduce this activity by showing them some (different varieties of) olives and olive oil and giving the brave ones a chance to have a taste. Ask the students if they know how olives grow, which parts of the world olives traditionally come from, and the common uses for olive oil. They may be surprised to learn that people are prepared to pay big money for this product.

A key to this activity is being able to recognise which information and what calculations are needed to prove or disprove each of Charlotte's deductions. For example, to prove or disprove the first statement (about the number of kilograms harvested), we need to find out how many trees Joan and Dave have and how much fruit each tree has. The calculation needed is: (number of trees) \times (amount of fruit) = $600 \times 20 = 12\,000 \text{ kg}$. This shows that Charlotte (who thought the harvest was $1\,200 \text{ kg}$) has made a place-value mistake.

If your students are having difficulty, put them in small thinking groups of three or four and get them to tackle one statement at a time. Read out a statement and ask them to answer these questions while you summarise their responses on the whiteboard:

1. *What question do we need to answer?*
2. *What information do we need to answer it?*
3. *What calculations should we do?*
4. *What is the answer to our calculation?*
5. *Is the statement true or false?*

Let's look at statement c by way of example:

1. Question: How many bins would Dave and Joan need for all their olives?
2. Information needed: the amount of olives they have ($12\,000 \text{ kg}$); the amount of olives that will fit in each bin (10 kg)
3. Calculation: amount of olives shared out into 10 kg bins: $12\,000 \div 10$

4. Answer: $12\ 000 \div 10 = 1\ 200$ bins
5. True or false? The statement is true.

After the groups have proved or disproved each statement, bring them back together and ask them to share their thinking. Each member of a group needs to be able to explain the answer as any one of them could be asked to report back. (This is an important rule because it helps everyone to stay involved and puts pressure on students to ask other members of their group for clarification if they don't understand something.) After a member of one group has been asked to prove or disprove a statement, other groups are given the opportunity to either agree with or refute that group's answer.

Note that many of the calculations rely on the answers to earlier calculations, so you need to stress to your students that if they are in doubt, they should cross-check with you.

In statement **e**, assume that the working days are all 8 hours long.

After the activity, promote reflective thinking by asking questions such as these:

- *Which number sense strategies did you find useful in this activity?*
- *What problems did you have? What did you do to overcome them?*
- *If you were helping someone else who was about to start this activity, what advice or tips would you give them?*

Achievement Objective

- perform measuring tasks, using a range of units and scales (Measurement, level 3)

AC
EA
AA
AM
AP

ACTIVITY

In this activity, students grapple with measuring the surface area of irregular solids, such as their body or a computer monitor. By working through it, they come to see that, regardless of the strategies they use, the best they can do is make estimates of the areas of irregular shapes or non-flat surfaces. They may find this frustrating; if so, use this as an opportunity to explain that all measurements are actually approximations: we can only measure as accurately as our devices will allow and our eyes can read.

Students will find the tasks much easier if you give them square grid paper with squares that are 1 cm by 1 cm. They are likely to need calculators for some of the computation involved.

Introduce the activity by asking the students what *area* is (the size of a surface) and how it is measured (usually in square units). All measurement involves comparing some attribute of an object with a suitable unit. We can then conclude that the object possesses so many of units of that attribute. The units are usually standard units, such as those on the list below, but sometimes we use informal units (for example, when we say that something is the length of 2 cricket pitches or weighs as much as a large car). This activity begins with an informal unit for area: an A4 sheet of paper.

As part of the discussion you have with your students, talk about area and shape. Students can be inclined to think of area as an attribute possessed only by regular mathematical shapes, especially rectangular ones. All objects, no matter how irregular, have surface area. It's just that irregular surfaces are harder to measure. This activity introduces them to challenges of this kind.

You could take the opportunity to list the everyday metric units for area:

square millimetre (mm ²)	for tiny areas
square centimetre (cm ²)	for small areas
square metre (m ²)	for areas such as rooms, houses, buildings, residential sections
hectare (100 m x 100 m or 10 000 m ²)	for big areas of land, including most farms
square kilometre (km ²)	for very large areas, such as forests, national parks, countries.

As they work through questions 2–5, your students are likely to find that the best strategy involves cutting the centimetre square grid paper into rectangles of suitable size and taping them to the body part so that there is minimum overlap. They may find it helps to label each of the smaller rectangles used with the number of its centimetre squares. Encourage them to look for and share short cuts and strategies. There is obviously no need to measure the surface of both arms separately. Measuring one arm carefully and doubling the result is going to be much quicker and will get a result that is at least as accurate. In question 4, they should aim to divide their objects into areas that are easy to work with; for example, the sides of a tote tray or a computer monitor may have areas that can be treated as rectangles.

After the activity, encourage reflective thinking by asking questions such as these:

- *What strategies did you find useful when measuring the surface areas of irregular solids?*
- *What did you do to try to be accurate? Could you show that your method was more accurate than another?*
- *What difficulties did you have? How did you overcome them?*
- *If two people measured the skin area of the same person, they would almost certainly get different results. Why? (Inconsistencies in defining where one region stops and another begins, differences in measuring technique, gaps and overlaps of the paper used for measuring, inaccurate counting of the 1 cm squares ...)*
- *How accurate do you think your measuring was? How close do you think you were to the true measure? Do you think your measurement was close enough to be of value?*

Achievement Objectives

- describe and interpret position, using the language of direction and distance (Geometry, level 2)
- make clockwise and anticlockwise turns (Geometry, level 2)
- perform measuring tasks, using a range of units and scales (Measurement, level 3)

ACTIVITY

In this activity, students create an orienteering course using their own units of length and quarter and half turns in the place of compass directions. They don't need much equipment and don't have to make any fancy measurements or calculations, but they do need to understand how the activity works and rigorously standardise their turns and lengths.

Play a quick game of "Simon Says" to practise turns, make sure that everyone knows their right from their left, and sort out clockwise and anticlockwise. Then give the group a series of oral instructions to follow, either by stepping them out or by moving a small plastic animal on the carpet. Get the students to give instructions to a classmate to step out the shape of the letter H or E. (Write the letter and show the callers secretly so their classmate has to guess the letter from the instructions.)

Make sure that the students are not too ambitious with the courses they set out. If the activity goes very well and they want to do it again, they can be more ambitious the second time.

A course is divided into stages. A stage is a set of moves that lead to a token. It is suggested that a course have about 5 or 6 stages. Instructions can be in the form of a simple (not-to-scale) diagram like the one in the student book or written, for example:

1. *Start on the steps of the medical room. Go forward 5 sticks, make a right turn, go forward 9 sticks. Find token 1.*
2. *Make a left turn. Go forward 13 sticks. Make a left turn. Go forward 20 sticks. Find token 2.*

The tokens are an important part of the activity. They give the student doing the course confirmation that they are on the right track and ready to begin the next stage, and they prove to the person who set the course that their classmate successfully navigated it.

If you are working with a whole class, the logistics of this activity will be simplified if you pair the students up and then send one person from each pair off to lay their course. When the courses are laid, the others take their instructions and go off to navigate them while the setters remain in the classroom. As the courses are navigated, students return to the classroom with their tokens and report to the classmate who set their course. When everyone has returned, discuss what the difficulties were, talk about how they were overcome, and collect advice for next time. Next time, reverse the roles for each pair of students.

Before the students set out to navigate their course, emphasise that in this activity, direction is always defined by comparing it to the previous direction. (North, south, east, and west play no part.) When they stop to locate a token, they must take care to remember exactly which direction they were facing before they stopped.

A variation on this activity is to turn the tokens into clues. When a student sets out on a course, they are only given instructions for the first stage. When they locate the token, it will have the instructions for the next stage written on it.

EXTENSION

Logo is a computer program designed for students. Using instructions exactly like those in this activity, they can guide the “turtle” (cursor) around, tracing a path as it goes. Logo instructions look like this: REPEAT 4[FORWARD 120 RIGHT 90]. Acting on these instructions, the turtle will take 120 steps forward, follow this by a right turn, and repeat both the actions that are inside the square brackets a further 3 times. The result is a square with sides 120 turtle steps long. Using Logo, students learn to be precise about their instructions at the same time as they create complex figures and designs on the screen.

Pages 20–21 Crow Ks

Achievement Objective

- draw and interpret simple scale maps (Geometry, level 3)

AC
EA
AA
AM
AP

ACTIVITY

In questions 1–4 of this activity, students interpret a simple diagram in order to describe distances and direction in terms of kilometres, compass directions, and degrees from north. No calculations are involved. Question 5 involves rates, and students will need to be Advanced Multiplicative thinkers (Number Framework, stage 7) to be able to complete it.

It is unlikely that students will be familiar with the kind of diagram on which this activity is based. It looks as if it is meant to be a map (given that it’s got towns and compass directions on it), but it doesn’t have all the other usual features of maps (such as roads, rivers, hills) and it does have those unusual concentric circles.

Introduce the activity with a discussion on the meaning of the phrase “as the crow flies”. The phrase refers to the shortest distance between two places: the length of the imaginary straight line joining them. Unlike us, a bird (crow) is not obliged to follow roads that wind around the natural and created obstacles like hills, rivers, lakes, and private property, which add length to a journey.

Scaffolding for question 1 could go like this: *Talor’s pōua (grandfather) says Riwai is 30 km away from where they are standing (the place marked with an X).*

- *If this is the case, how far would the crow have flown when it crossed (any point on) the first circle? (15 km, because it is halfway between the X and Riwai)*
- *So what does the gap between each circle mean in terms of distance? (Each circle marks off another 15 km distance from Talor and his pōua.)*
- *How could you use this information to help you work out the distance to Browns? (You’d have to estimate that Browns is about $\frac{2}{3}$ of the way along the distance between the second and the third circles; $\frac{2}{3}$ of 15 km is 10 km. $15 + 15 + 10 = 40$ km)*

The information panel for question 2 explains how directions should be worded. Most students won't have met the terminology "due west", so explain that this means "directly west" and is used to make it clear that we are not talking about a direction that is just more or less westerly. Explain also that in addition to the 4 cardinal points of the compass, there are 4 intercardinal points: north-west, north-east, south-east, and south-west. Like the cardinal points, the word "due" can be used with them to make it clear that we mean precisely that direction. Question 3 hinges on the word *equidistant*; its meaning is explained in the information panel.

Question 4 is about giving direction as a number of degrees measured clockwise from due north. The diagram shows the degree equivalent for each of the 4 cardinal points, and students have to estimate the direction of each town. It is usual to express bearings as 3-digit numbers (for example: 005°, 059°, 184°).

Note that direction by compass points (question 2) and direction by bearings in degrees (question 4) are two different systems that get along comfortably together. Students may wonder why there are two systems. The reasons are historical. The first is older, less precise, and more clumsy. (It's difficult to specify a direction that is not conveniently halfway between two named directions.) The second is more recent, precise, and allows for any direction to be specified with equal ease. Both systems reflect the navigational needs of their times.

If students find question 5a difficult, encourage them to draw a double number line and ask them questions that will scaffold their thinking.

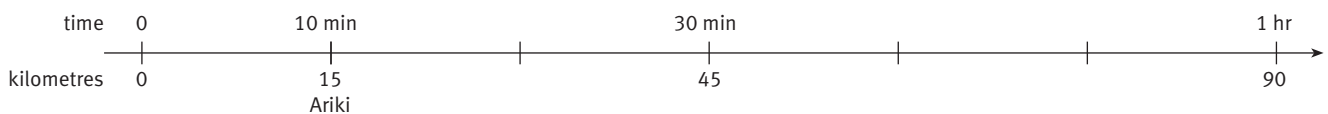

- *If the pair travelled for a whole hour at 90 km/h, how far would they get? (90 km) Show this on your number line.*
- *How far would they have travelled in half an hour? (45 km)*
- *How far away is Ariki? (15 km)*
- *Where on the line would you put 15 km? ($\frac{1}{3}$ of the way between 0 and 45 km, or $\frac{1}{6}$ of the way between 0 and 90 km)*
- *How could you use the numbers on the double number line to work out how long it would take to travel 15 km at 90 km/h? ($\frac{1}{3}$ of 30 minutes is 10 minutes, or $\frac{1}{6}$ of 60 minutes is 10 minutes)*

In question 5b, the car takes 36 minutes to travel 60 km:

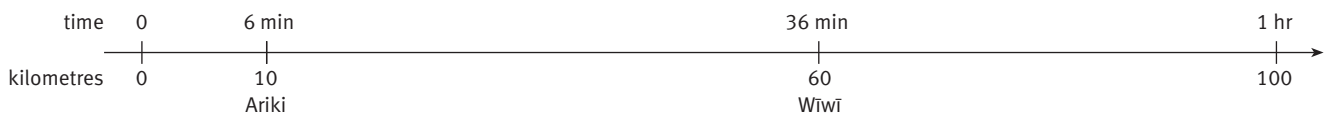

- *How far would the pair have travelled in 6 minutes? Show where you'd put 6 minutes on your number line.*
- *Now that you know they travelled 10 km in 6 minutes, can you use that to work out how far they would have gone in 1 hour if they'd kept going at the same speed?*
- *What speed are you doing if you travel 100 km in 1 hour? (100 km/h)*

In question 5c, the car takes 30 minutes travelling at 90 km/h to reach a particular town:

- *How far would the car get if it travelled for a whole hour at this speed? (90 km)*
- *They only travel for half an hour, so what part of 90 km should they cover in this time?*
- *Which towns are 45 km from X? (Melthorn and Pihikete)*

EXTENSION

If your school has a set of orienteering compasses, show your students how to use these and then get them to find the bearings (in degrees, clockwise from north) of various points around the school, taken from a variety of vantage points. This could lead into some simple orienteering. (Going Places, page 19, could be used as a starting point.)

Achievement Objectives

- draw and interpret simple scale maps (Geometry, level 3)
- specify location, using bearings or grid references (Geometry, level 4)

AC
EA
AA
AM
AP

In this activity, students use grid references to solve a puzzle and to play a variation on the Battleships game.

ACTIVITY

Ensure that your students know that co-ordinates are number pairs, used to specify the location of points on a grid (or points in a plane). They are arranged with the value from the *x*-axis (horizontal axis) first and the value from the *y*-axis (vertical axis) second. So the point (2, 3) is found 2 steps along from the origin (0, 0) and 3 steps up. To check that your students understand this, ask them to tell you what the co-ordinates are for the “D” of “Dog kennel” on the map in the student book (17, 9).

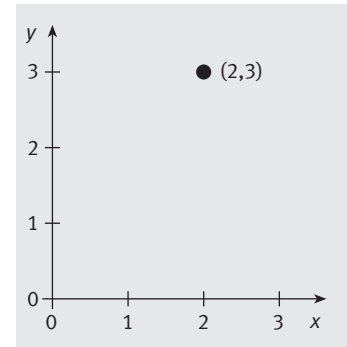

Some students will find the language of Jake’s poem quite difficult. Avoid going through it line by line and explaining what it means. This would rob the students of the excitement that comes from working it out for themselves. Put the students into small mixed-ability problem-solving groups of three or four and let them puzzle their way through it, asking for teacher help only when they need it. Tell them to keep the secret when they learn it so that others can discover it for themselves.

When they have circled the letters identified by the co-ordinates, the students should start with the letter E and count on to the next circled letter, making note of the “distance” (number of letters) from the first to the second. They then count from the second circled letter to the third, and so on, noting the distance each time. When they reach the end of the alphabet, they loop back to the beginning (like this: ... W X Y Z A B C D ...), stopping when they reach the letter D (the last “3”). When they add the distances together, they should get $1 + 6 + 2 + 4 + (4 \times 3) = 25$.

The solution to the riddle hinges on the three mathematical words in the second line of the final stanza: co-ordinate, factors, and square:

- *Co-ordinate* was introduced and explained at the beginning of this activity in the usage “a pair of co-ordinates”; here it is being used in a different and unusual way, as a verb meaning “write as a pair of co-ordinates”.
- The students will have met the word *factors* before but may have forgotten what it means. Factors are numbers that are whole-number divisors of another number. For example, 1, 2, 3, 4, and 6 are all factors of 12 because they divide into 12 without remainder. In the case of Jake’s riddle, the students need to find the factors of the “special number” referred to. There are in fact two pairs of factors, but only one pair gives the co-ordinates of a point that lies on the map.
- *Square* is being used here to mean a “square number”, not a geometrical square. If your students don’t know this meaning of the word, give it to them when they need it, not at the beginning. Here are the first four square numbers:

$1 \times 1 = 1$



$2 \times 2 = 4$



$3 \times 3 = 9$



$4 \times 4 = 16$



GAME

The treasure game is an adaptation of the traditional Battleships game. The main differences are that in the traditional game, the grid references consist of a number and a letter (for example, 5H) and define cells, not points.

The rules are as follows:

- The game is for two players or two teams of two.
- Each person or team has a map showing where treasure is hidden. The islands are the same for each player, but the treasure is in different locations.
- Players take turns at guessing where the treasure is hidden on their opponent's map.
- Each time a player makes a guess, the other player says "miss" or "hit". If it is a hit, the other player tells the first player which letter they hit (but not which treasure). Using their empty map, the first player records a dot for a miss or the letter for a hit.
- A player tells the other when they have successfully excavated (hit all the letters of) a particular treasure.
- Players keep taking turns until the treasure has been located and excavated.
- Points are awarded for each successful excavation, depending on the nature of the treasure and who found it first. See the student book for the scoring system.

To conclude this activity, use questions such as these to promote reflective thinking:

- *Where have you seen grid references used in real life?* (Map books, graphics in newspapers, crosswords, orienteering courses, seating arrangements ...)
- *Grid references don't always use two numbers, but sometimes letters and numbers, such as A3. Why might this be?* (Perhaps to make it easier for people to interpret if they don't know how to read co-ordinates. There is less chance of confusion.)

Sorry to Disturb You!

Achievement Objectives

- read and interpret everyday statements involving time (Measurement, level 3)
- perform calculations with time, including 24-hour clock times (Measurement, level 4)

AC
EA
AA
AM
AP

This activity gives students opportunities to explore the effects of crossing the International Date Line and to work out what time it is in different countries and time zones, using the information in the phone directory.

ACTIVITY

The International Date Line is an imaginary north–south line on the surface of the Earth that allows us to define the time of day with precision and separates "today" and "tomorrow". Many students do not realise that 24-hour time is a human construct and that the lines of longitude that enable us to assign a time to any place on the planet were set in place in recent history in response to navigational needs. A very interesting mathematical and historical investigation could be based around this topic.

The International Date Line follows the 180° meridian (on the opposite side of the Earth to the 0° meridian, which goes through the Greenwich Observatory in London), zigzagging around eastern Russia and making a major detour in the Pacific Ocean to ensure that all the islands of Kiribati are on the same side.

You could introduce this activity by using a torch to represent the Sun (and daytime) and a globe that shows the International Date Line. Show the students how the Sun shines on different parts of the world as the Earth spins on its axis. Try these questions as discussion starters:

- *What countries are on the opposite side of the Earth from New Zealand?*
- *What time would you expect it to be there when it's lunchtime here?*
- *Which way does the Earth spin on its axis, given that the Sun rises in the east and sets in the west?*
- *Where on the surface of the globe should you look for sunrise and sunset?*

When introducing question 1, ask your students if they have ever lost or gained time when travelling overseas. Get them to talk about their experience of moving forwards or backwards through time zones and how this often affects sleep.

Using a globe or a soccer ball and a paper dart or a toy aeroplane, ask the students to try to explain how Courtney missed her birthday. Ask them to try to explain how, if she timed it correctly, she could use international travel to have 2 birthdays in 1 year. (She could manage this if she left on the day of her birthday and crossed the International Date Line from west to east, gaining 24 hours.) Ask “*Would this mean that she went from age 11 to age 13 in 24 hours?*”

When doing questions 2 and 3, students may find it helps them to visualise what is going on if they have an analogue clock that they can turn backwards. If they do use a clock, they will need to keep track of whether it is morning or evening and what day it is if they move back past midnight. Explain that a.m. is the abbreviation for *ante meridiem* (Latin for “before noon”) and p.m. is the abbreviation for *post meridiem* (Latin for “after noon”).

Students who know the part-whole strategy “building to a tidy number” can be encouraged to apply the strategy to this problem, using 12 noon and 12 midnight as tidy numbers. 18 hours before 9 a.m. on Wednesday can then be solved in this way: “If we subtract 9 hours from 9 a.m., we get back to 12 midnight on Tuesday; if we then subtract 9 more hours (to make the total of 18 hours), we get back to 3 p.m. on Tuesday.” Using a number line, we can illustrate these two steps like this:

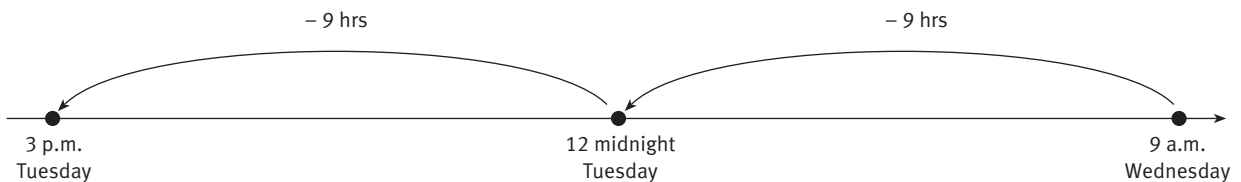

The note in the phone book “No provision has been made for daylight saving at either end” is a reminder that the times in the phone book are based on Greenwich Mean Time and that many countries put their clocks forward by an hour during the summer months. (GMT is still widely used, though technically superseded by atomic time.) This is to take advantage of the extra daylight in summer that comes as a result of the tilt in the Earth’s axis, which brings us closer to the Sun.

If we know that a country has daylight saving or “summer time” at the moment, they will be 1 hour less behind us than the number stated in the phone directory because they will have put their clocks forward. When it is summer in the United Kingdom, they are 11 hours behind us instead of 12. However, when New Zealand is on daylight saving time, we are forward by an extra hour, meaning that in our summer months, we are actually 13 hours ahead of the United Kingdom. There are only a few weeks of the year when neither the United Kingdom nor New Zealand is on daylight saving time and when, as a consequence, we are exactly 12 hours apart. Some students may wish to do some research into daylight saving or Greenwich Mean Time.

If students want to make sure their calculations take account of daylight saving times, there are a number of websites that have this information, including www.whitepages.co.nz/world-directories

At the conclusion of this activity, use these suggestions to encourage your students to reflect on what they have learned:

- *Why doesn’t New Zealand need to have different time zones within our country?* (Because we are long and thin and orientated north–south, so the Sun rises and sets at a similar time throughout the country. By contrast, in Australia there is a big distance between the east and west coasts of the continent, so they have 2 hours’ difference between Sydney in the east and Perth in the west.)
- *Share something interesting or new to you that you found out from this activity or from your research.*

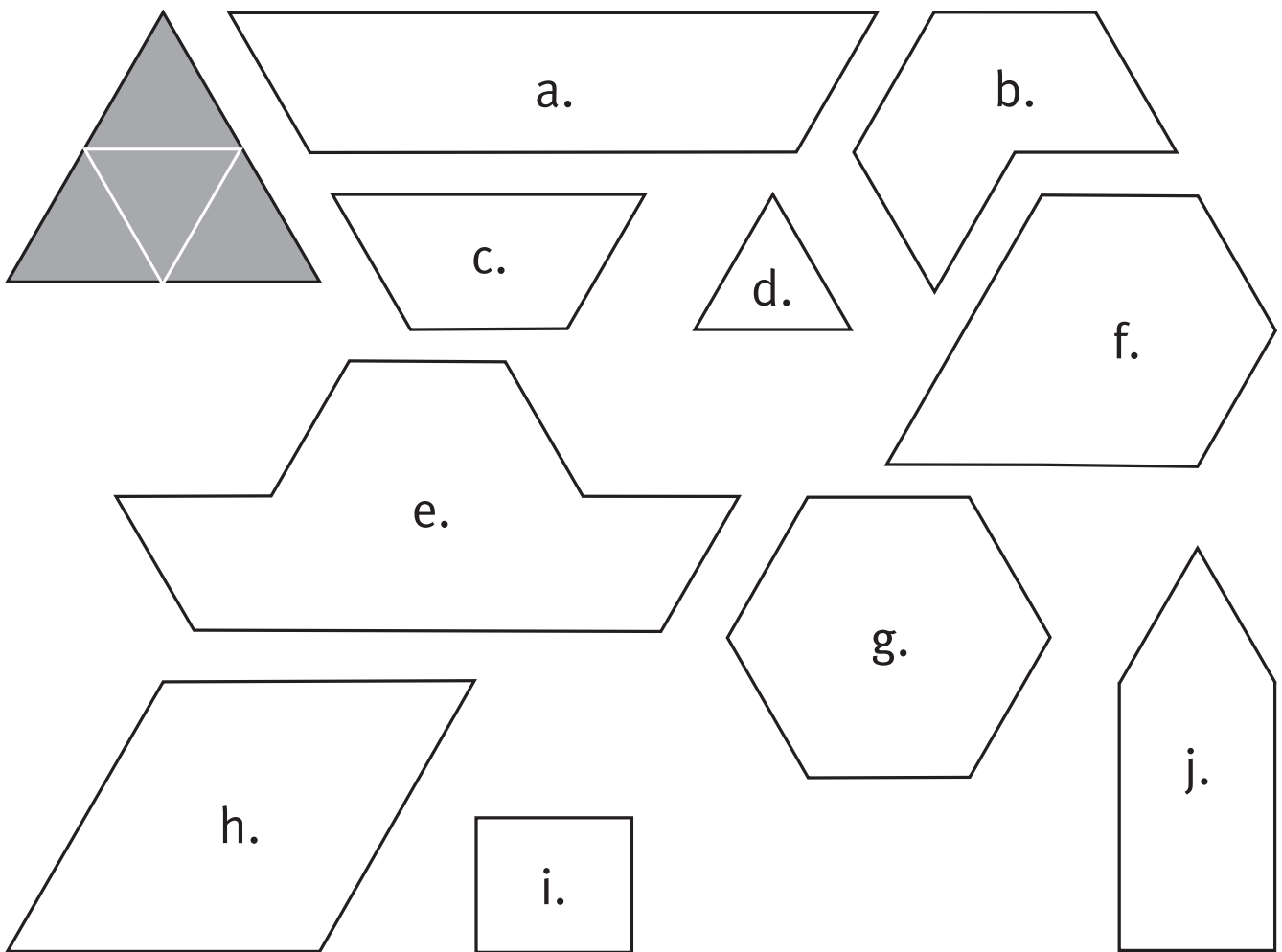
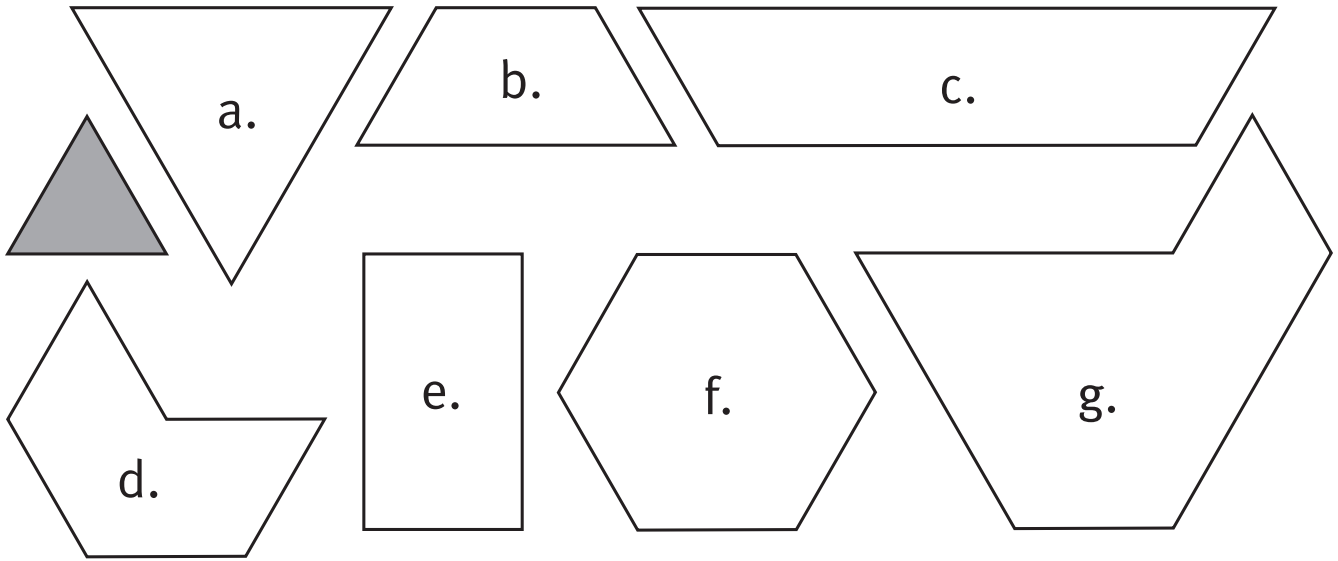

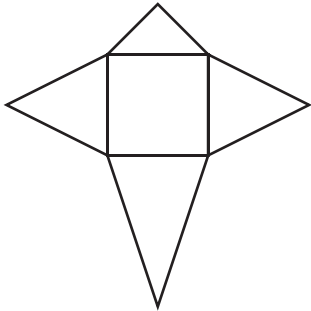
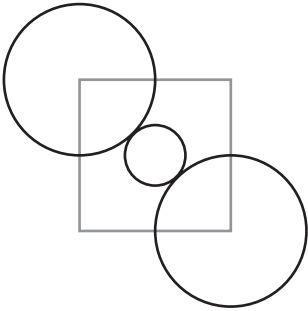
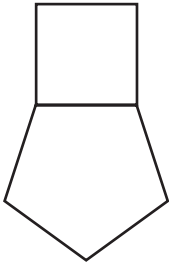
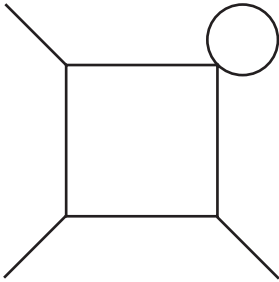
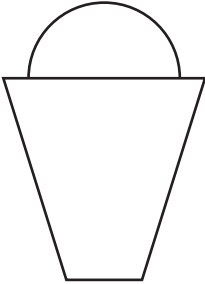
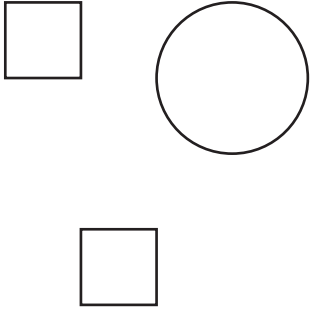
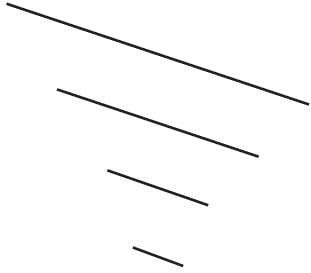
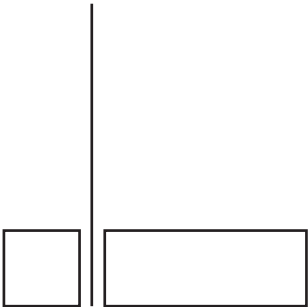
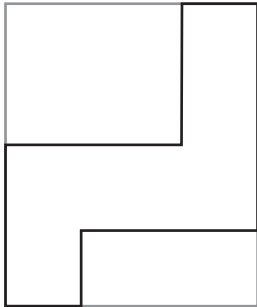

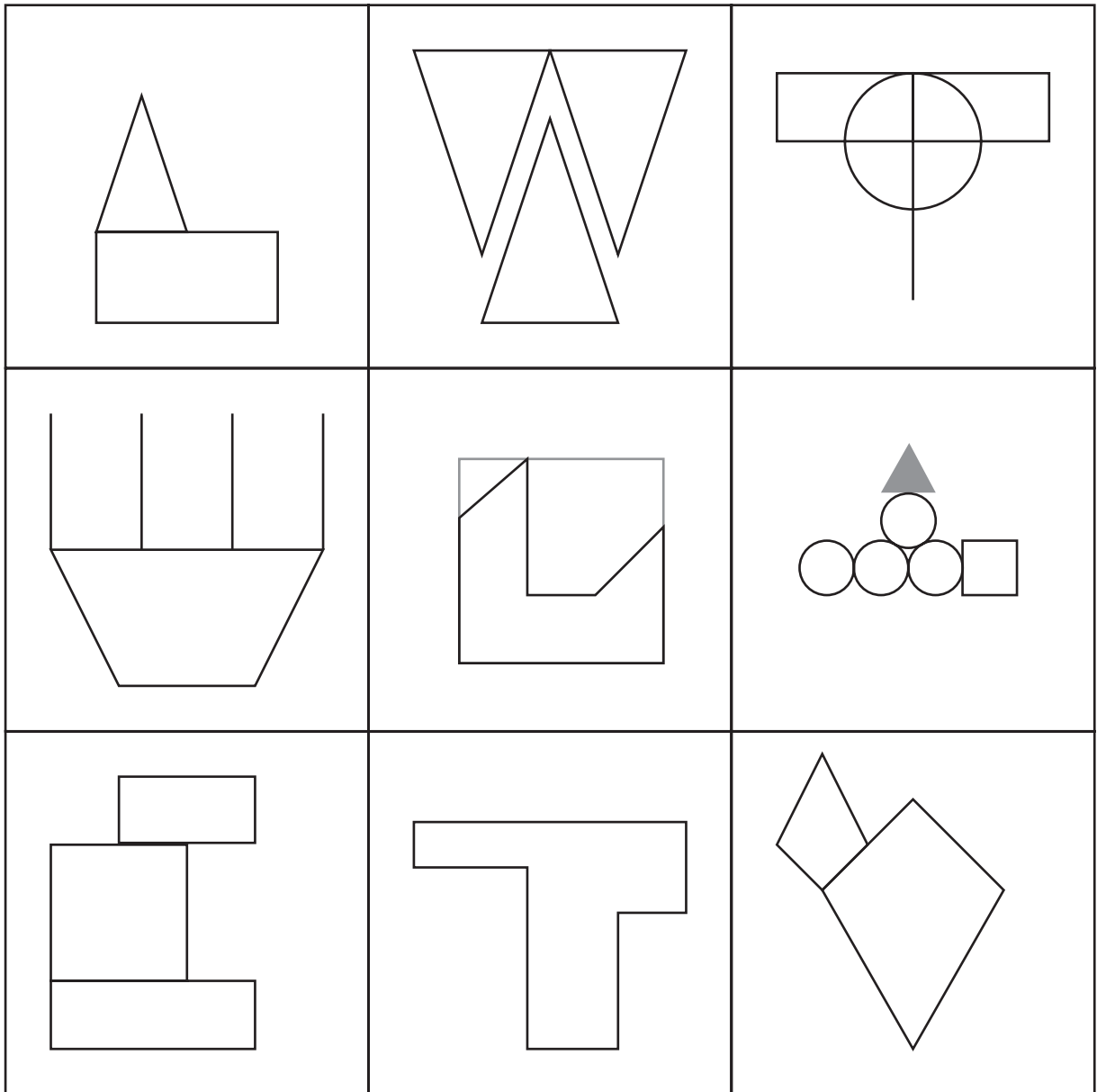

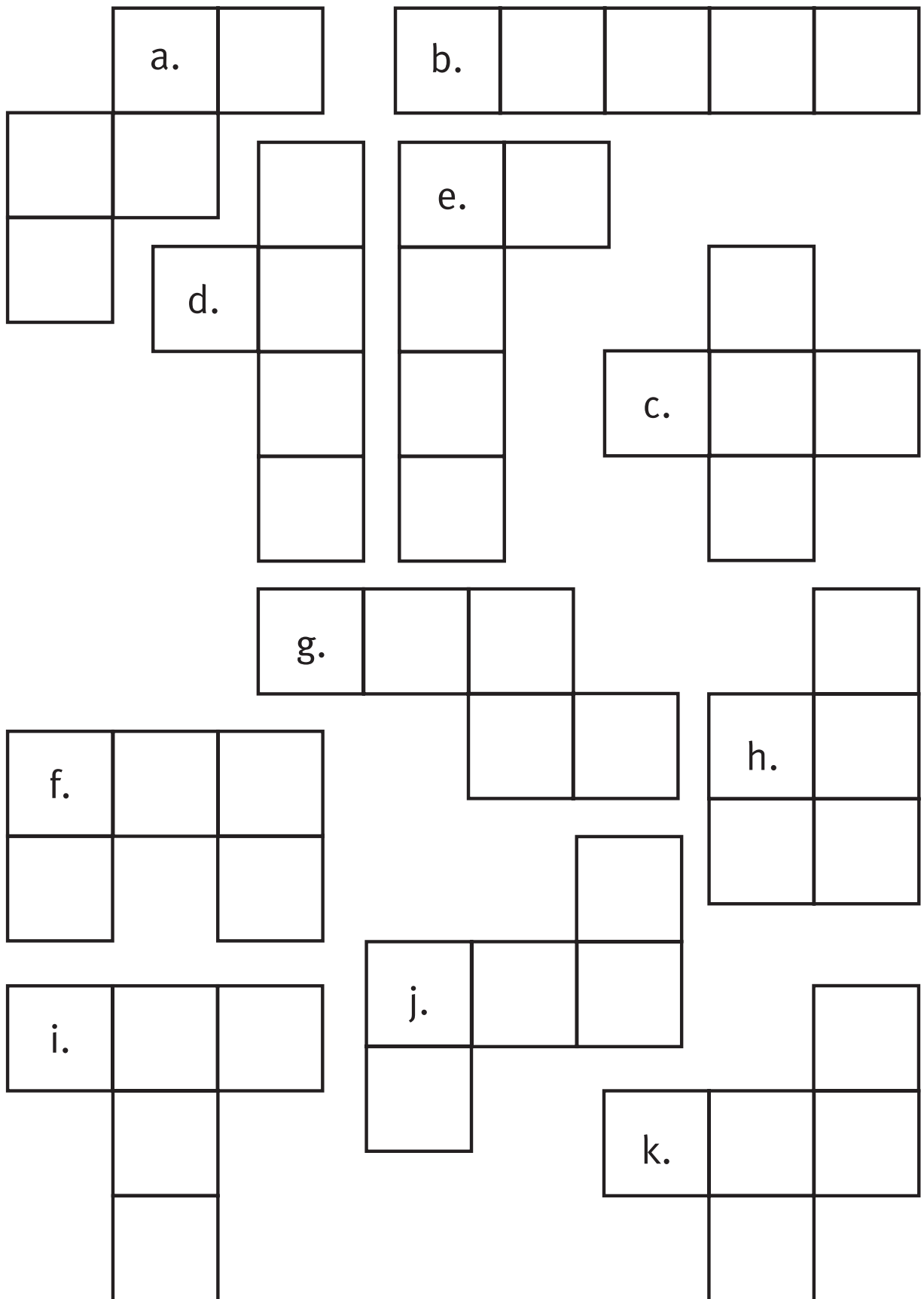

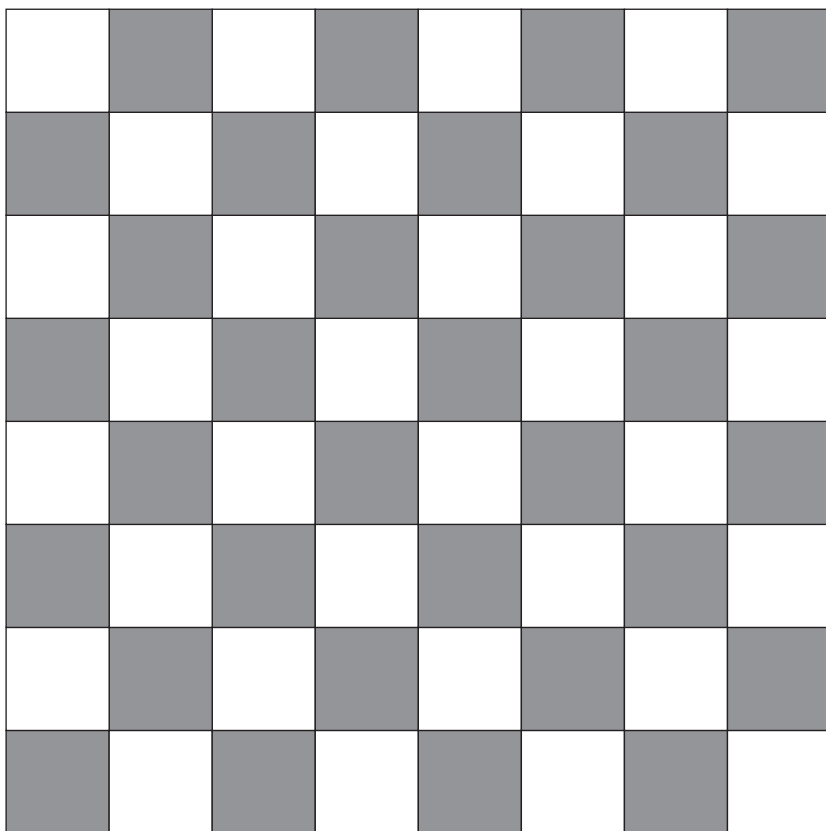
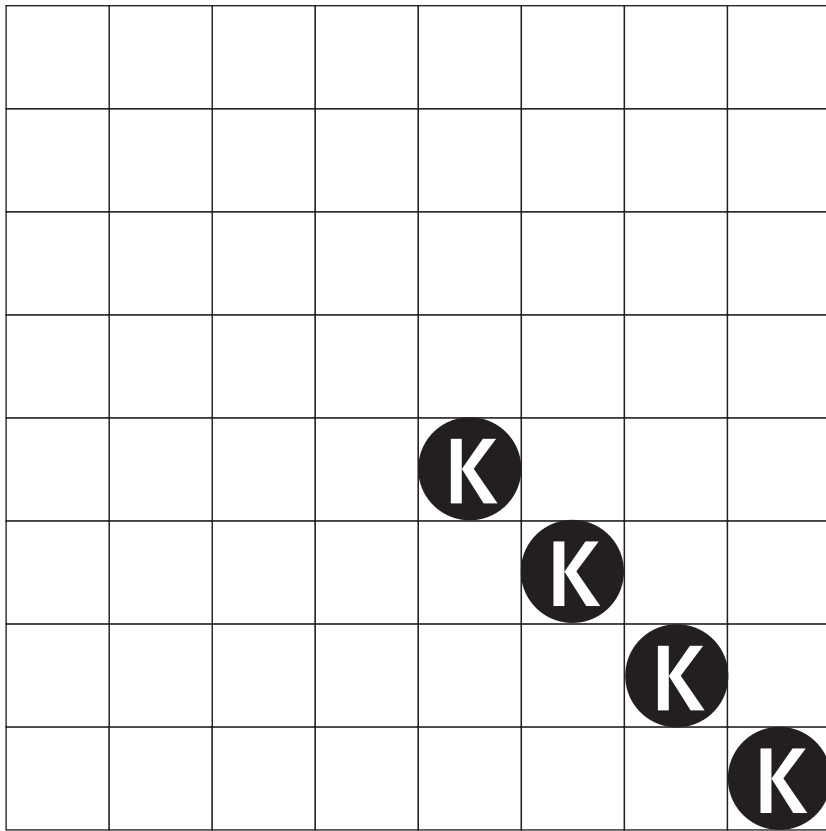

Circle the letters as your opponent strikes them. Name each letter they hit.

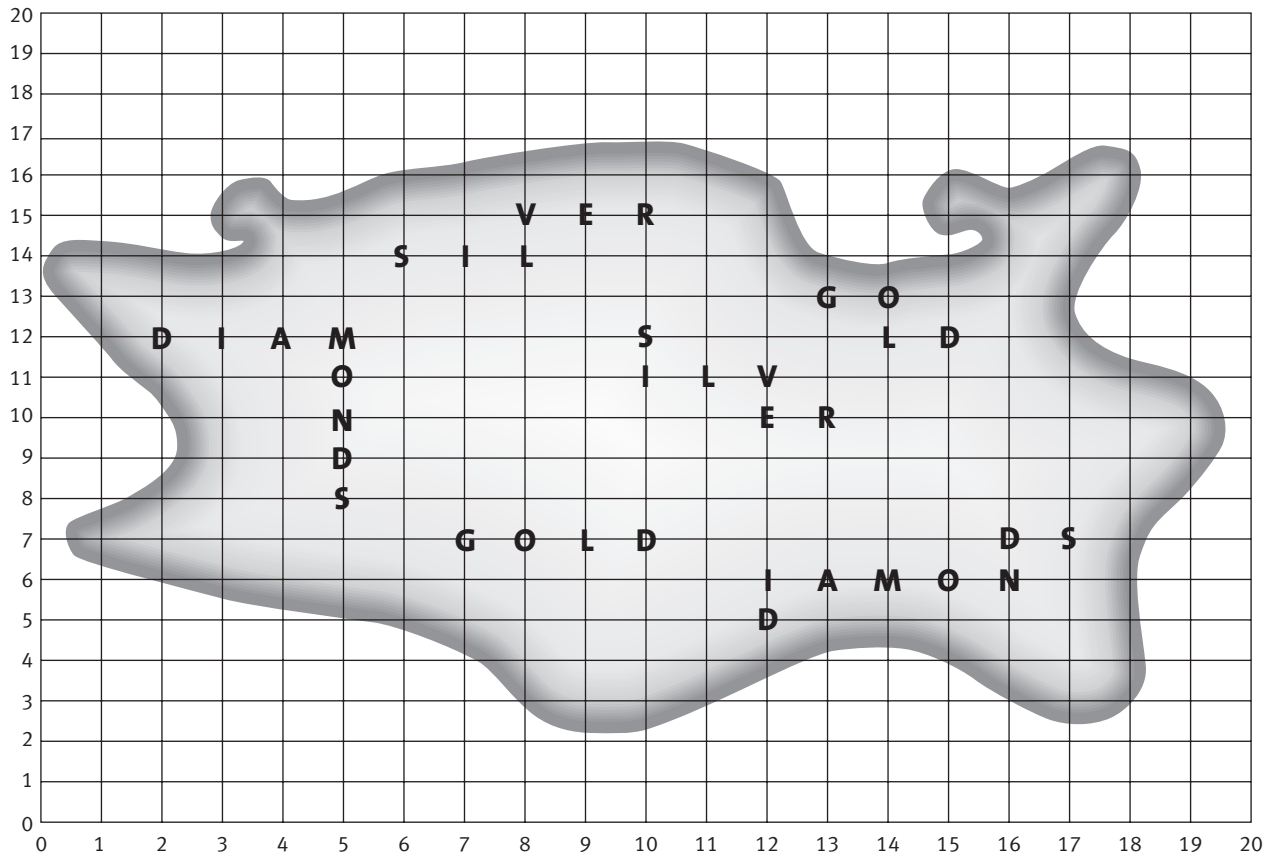

Use this map to mark points as you try them and treasure as you find it.

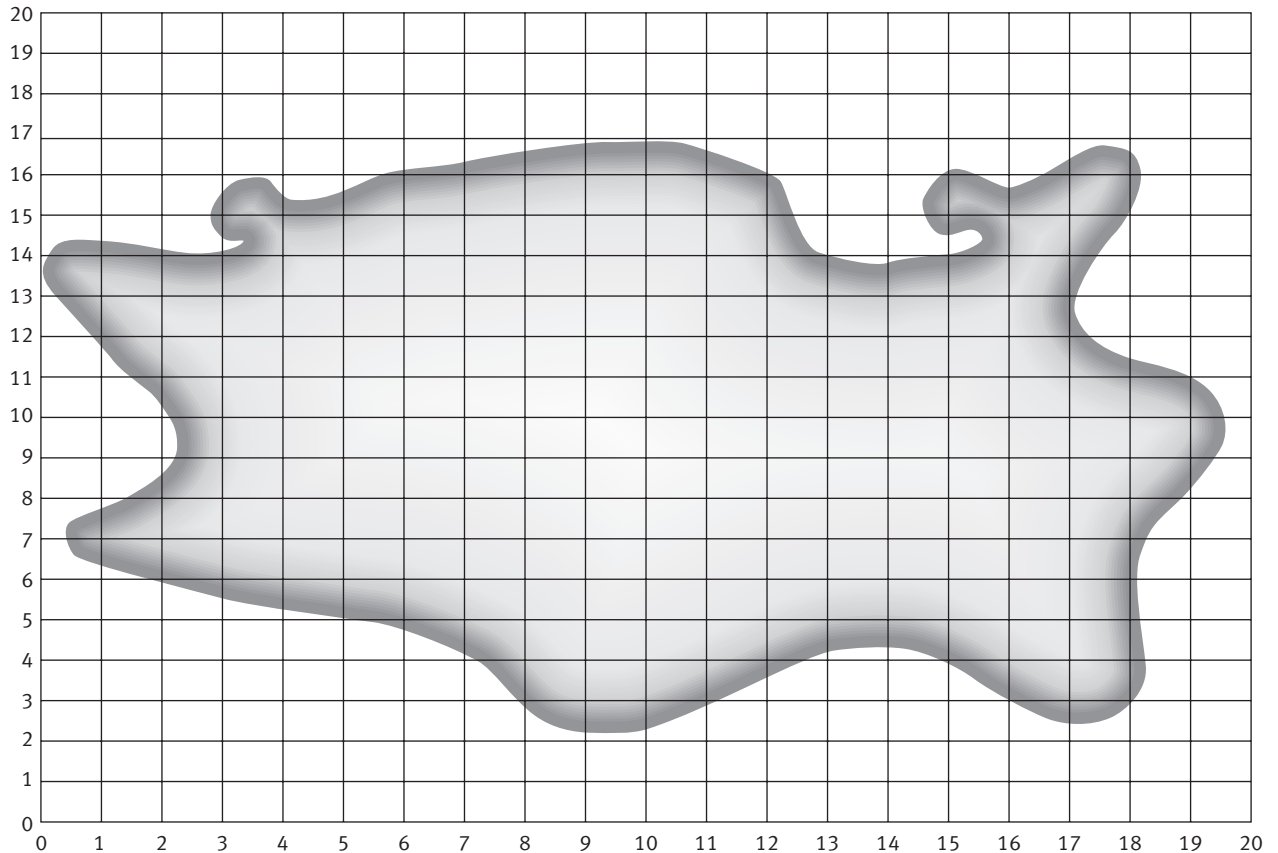

Circle the letters as your opponent strikes them. Name each letter they hit.

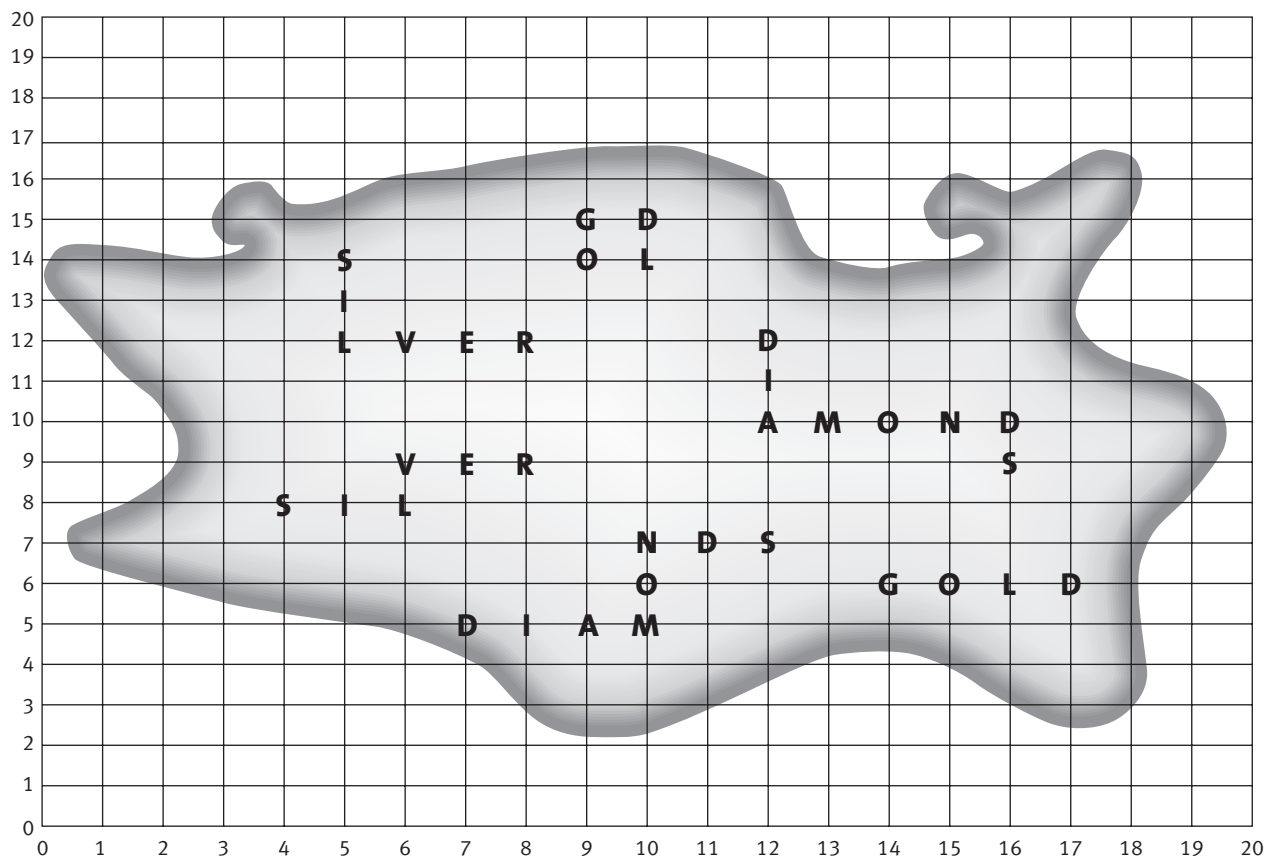

Use this map to mark points as you try them and treasure as you find it.

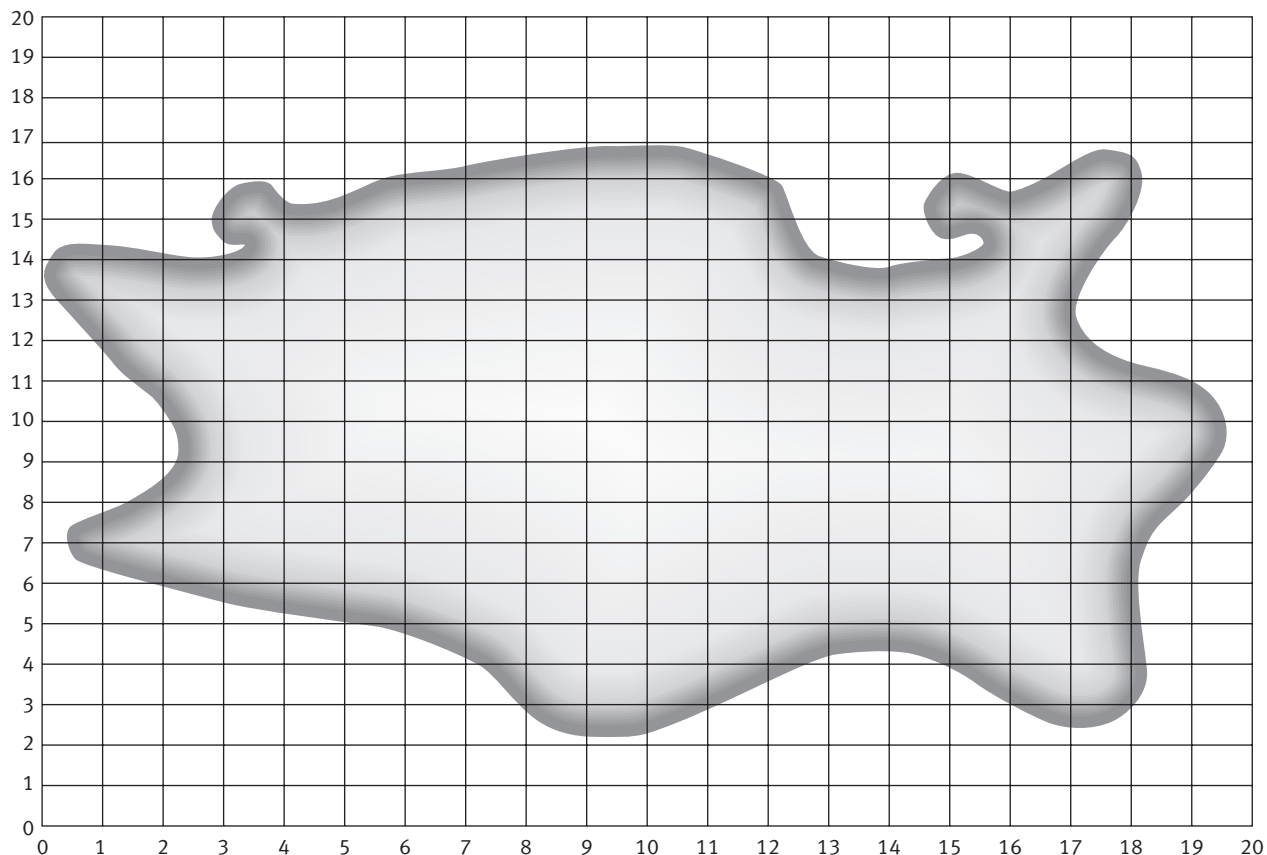

ACKNOWLEDGMENTS

Learning Media and the Ministry of Education would like to thank Kirsten Malcolm, Auckland, for developing these teachers' notes.

The photograph of the student on the cover is by Mark Coote and Adrian Heke. The illustration on the cover is by Ben Galbraith.

Other illustrations and diagrams are by Bunkhouse graphic design.

All these images are copyright © Crown 2006.

Series Editor: Susan Roche

Editor: Ian Reid

Designer: Bunkhouse graphic design

Published 2006 for the Ministry of Education by
Learning Media Limited, Box 3293, Wellington, New Zealand.
www.learningmedia.co.nz

Copyright © Crown 2006

All rights reserved. Enquiries should be made to the publisher.

Dewey number 516

ISBN 0 7903 1345 6

Item number 31345

PDF ISBN 0 7903 1352 9

Students' book item number 31344