

Answers and Teachers' Notes

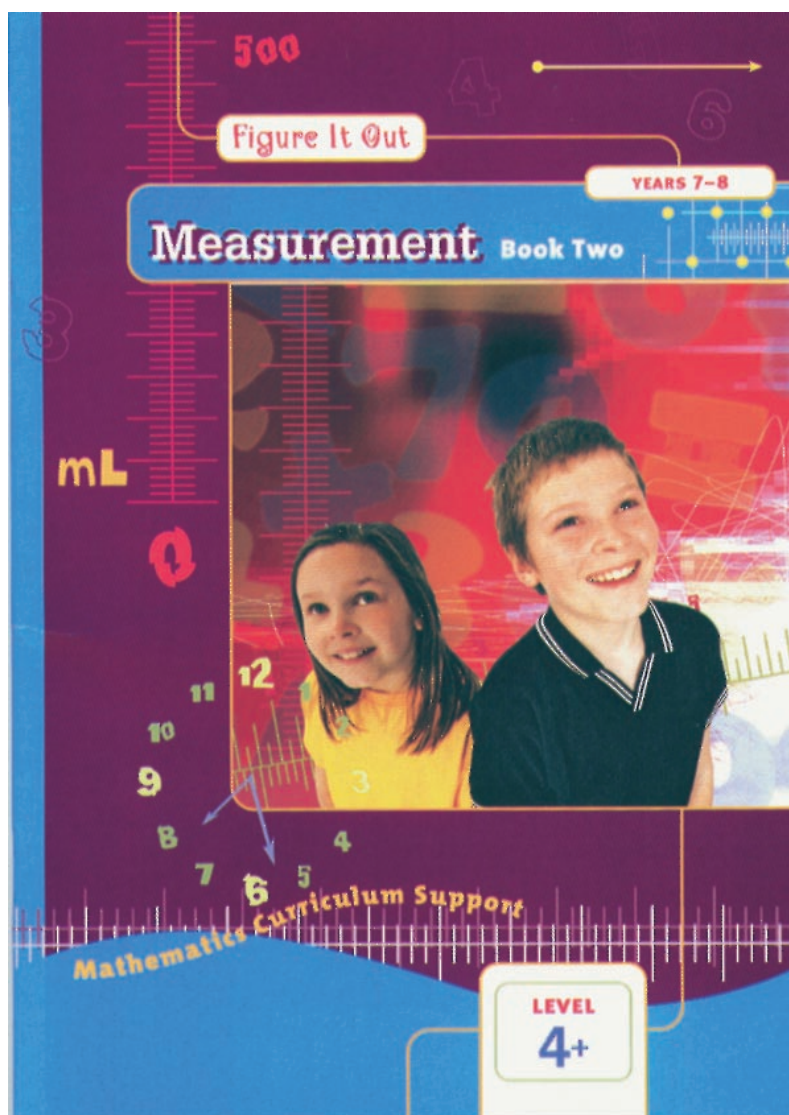

MINISTRY OF EDUCATION
Te Tāhuhu o te Mātauranga

CONTENTS

Introduction	2
Answers	3
Teachers' Notes	9
Copymaster	28

The books for years 7–8 in the Figure It Out series are issued by the Ministry of Education to provide support material for use in New Zealand year 7–8 classrooms. The books have been developed and trialled by classroom teachers and mathematics educators and follow on from the successful series for levels 2–4 in primary schools.

Student books

The student books in the series are divided into three curriculum levels: levels 2–3 (linking material), level 4, and level 4+ (extension material). All the books are aimed at year 7–8 students in terms of context and presentation.

The following books are included in the series:

Number (two linking, three level 4, one level 4+, distributed in November 2002)

Number Sense (one linking, one level 4, distributed in April 2003)

Algebra (one linking, two level 4, one level 4+, distributed in August 2003)

Geometry (one level 4, one level 4+, distributed in term 1 2004)

Measurement (one level 4, one level 4+, distributed in term 1 2004)

Statistics (one level 4, one level 4+, distributed in term 1 2004)

Themes: *Disasters Strike!*, *Getting Around* (levels 4–4+, distributed in August 2003)

The activities in the student books are set in meaningful contexts, including real-life and imaginary scenarios. The books have been written for New Zealand students, and the contexts reflect their ethnic and cultural diversity and life experiences that are meaningful to students aged 11–13 years. The activities can be used as the focus for teacher-led lessons, as independent bookwork, or as the catalyst for problem solving in groups.

Answers and Teachers' Notes

The Answers section of the *Answers and Teachers' Notes* that accompany each of the student books includes full answers and explanatory notes. Students can use them for self-marking, or you can use them for teacher-directed marking. The teachers' notes for each activity, game, or investigation include relevant achievement objectives, comment on mathematical ideas, processes, and principles, and suggestions on teaching approaches. The *Answers and Teachers' Notes* are also available on Te Kete Ipurangi (TKI) at www.tki.org.nz/r/maths/curriculum/figure

Using Figure It Out in your classroom

Where applicable, each page starts with a list of equipment that the students will need to do the activities. Encourage the students to be responsible for collecting the equipment they need and returning it at the end of the session.

Many of the activities suggest different ways of recording the solution to a problem. Encourage your students to write down as much as they can about how they did investigations or found solutions, including drawing diagrams. Discussion and oral presentation of answers is encouraged in many activities, and you may wish to ask the students to do this even where the suggested instruction is to write down the answer.

The ability to communicate findings and explanations, and the ability to work satisfactorily in team projects, have also been highlighted as important outcomes for education. Mathematics education provides many opportunities for students to develop communication skills and to participate in collaborative problem-solving situations.

Mathematics in the New Zealand Curriculum, page 7

Students will have various ways of solving problems or presenting the process they have used and the solution. You should acknowledge successful ways of solving questions or problems, and where more effective or efficient processes can be used, encourage the students to consider other ways of solving a particular problem.

Answers

Measurement: Book Two

Page 1

Light and Sound

ACTIVITY

- Practical activity. Results will vary.
- Results will vary, but they should be approximately 300–350 m/s.
For example, if, over four trials, the time for sound to travel 300 metres averages 0.9 seconds:
Speed = distance in metres \div time in seconds
= $300/0.9$ or $300 \div 0.9$
= 333 m/s
- Results could be improved by increasing the distance and using a starting pistol instead of wooden blocks.
- Individual activity

Pages 2–3

Plentiful Plankton

ACTIVITY

- 5.7 mm
 - 5 700 micrometres (μm)
- 1.8 mm or 1 800 μm
 - 2.6 mm or 2 600 μm
 - 1.4 mm or 1 400 μm
 - 8.4 mm or 8 400 μm
- $\times 75$
 - $\times 30$

Pages 4–5

Fat in Foods

ACTIVITY

Note that all numbers and answers in this activity are approximate.

1. a. (and 2b)

Food	Mass (grams) per gram of fat	Muffin equivalent
Fried egg	3 g	$\frac{1}{2}$ egg
Milk	29 g	1 glass
Banana	150 g	7 bananas
Lean steak	9 g	$\frac{1}{2}$ steak
Yoghurt	38 g	2 pots
Bread	39 g	7 slices
Chocolate	3 g	3 squares
Biscuits	10 g	3 biscuits
Hamburger	7 g	$\frac{1}{5}$ hamburger
Cereal biscuits	28 g	7 cereal biscuits
Broccoli	180 g	1.2 kg broccoli
Potato crisps	3 g	$\frac{1}{5}$ packet (20 g)
Apple	1 400 g	70 apples
Cheese	3 g	20 g
Drumstick	7 g	1 drumstick
Fries	7 g	$\frac{1}{4}$ large fries
Pork chop	13 g	1 chop
Toffee biscuits	5 g	2 biscuits

- Meat, dairy, and fried products tend to be high in fat content because animals produce and store fat.
 - Vegetables and fruit
- 7 g. ($100 \div 12 \times 0.8 = 6.67$)
 - See table under 1a, above.
 - Answers will vary.

INVESTIGATION

Answers will vary.

ACTIVITY ONE

1. 4:3. ($47.2 \div 35.4 = 1.33$
 $= \frac{4}{3}$)

2. The dimensions of the televisions are as follows:

	Width (cm)	Height (cm)	Diagonal (cm)
a.	27.2	20.4	34
b.	38.4	28.8	48
c.	54.4	40.8	68
d.	16	12	20

3. a. A normal screen with a height of 9 units would have a width of 12 units, while a wide screen 9 units high would have a width of 16 units. So a wide screen is $\frac{16}{12} = \frac{4}{3}$ the width of a normal screen.

b.

	Width (cm)	Height (cm)	Diagonal (cm)
i.	48	27	55
ii.	32	18	36.8
iii.	40	22.5	46

ACTIVITY TWO

- 24 cm x 16 cm
- 19.2 cm x 12.8 cm
- 13.3 cm x 8.9 cm
- 12 cm x 8 cm

ACTIVITY

- Practical activity. The total surface area is 34 squares (square units).
- a. Practical activity
b.–c.

Model dog	Volume in cubes	Surface area (number of exposed cube faces)	Ratio of surface area to volume (to 2 decimal places)	
i.	8	34	34 : 8	4.25 : 1
ii.	13	54	54 : 13	4.15 : 1
iii.	16	52	52 : 16	3.25 : 1
iv.	64	136 (34 x 4)	136 : 64	2.13 : 1

d. As body size increases, the ratio of surface area (skin) to volume decreases.

- e. A small dog has proportionally more surface area (skin) than a large dog, so it loses or gains heat more rapidly and is less able to cope with extremes.

INVESTIGATION

Results will vary. Hypothermia is a loss of body heat, which leads to death if not stopped in time.

ACTIVITY

- Answers will vary. Suggested ranges are:
 - 58–62%
 - 49–51%
 - 55–57%
 - 52–54%
- Practical activity

ACTIVITY

- Approximately 12 p.m. (noon)
- Approximately 3.10 p.m.
- Approximately 5.30 a.m. and 11.50 a.m.
- Approximately 1.85 m. (2.25 – 0.4)
- Approximately 3.30 a.m. on Tuesday
- The reason is the start of daylight saving. Tsunami or other natural causes can't be the explanation because tide tables are prepared weeks or months in advance and such causes can't be predicted.

Pages 12–13 The Big Drip

ACTIVITY ONE

- Answers will vary but should be close to 183 m^2
- Answers will vary but should be in the range $74\text{--}78 \text{ m}^2$. 76 m^2 is a good estimate. Your markings on your copy of the copymaster should show how you reached your answer.
- Answers will vary, depending on your answers for questions 1 and 2. If an area of 76 m^2 is flooded, this is 42% of 183 m^2 , to the nearest whole percent.
 - Approximately 2:3. (If 42% is flooded, 58% is not. As a ratio, this is 42:58, which is approximately 40:60 or 2:3.)

ACTIVITY TWO

- 7 m^2 . (2.8×2.5)
 - 16.8 m^3 . ($2.8 \times 2.5 \times 2.4$). The fact that the room contains a vanity, bath, and shower will make little difference; water will occupy their spaces too.
- 14 hrs. (At 200 L every 10 minutes, the water is coming in at the rate of 1 200 L every 60 minutes. 1 200 L is equivalent to 1.2 m^3 . The time taken in hours for the room to fill is:

$$\text{volume of room} \div \text{rate per hour} = \frac{16.8}{1.2}$$

$$= 14 \text{ hrs.}$$
)
- 3.45 m^2
- Individual activity. Answers will vary.

Pages 14–15 Colossal Kiwifruit

ACTIVITY ONE

- 33.0 m . ($\pi \times 10.5$)
 - 64.4 m^2 . (33.0×1.95)
- 86.6 m^2 . ($\pi \times 5.25^2$)
 - 4.91 m^2 . ($\pi \times 1.25^2$)
- 10.7 L . (2 coats on the skin means $2 \times 64.4 = 128.8 \text{ m}^2$ to be painted. At 12 m^2 per litre, this is $\frac{128.8}{12} = 10.7 \text{ L}$.)
 - 1.64 L . (Total area to be painted is $2 \times 2 \times 4.91 = 19.64 \text{ m}^2$. Paint needed is $\frac{19.64}{12} = 1.64 \text{ L}$.)
 - 27.2 L . (Each green face has an area of $86.6 - 4.91 = 81.7 \text{ m}^2$. Total area to be painted is $2 \times 2 \times 81.7 = 326.8 \text{ m}^2$. Paint needed is $\frac{326.8}{12} = 27.2 \text{ L}$.)

- Cylinder (or circular prism)
 - 169 m^3 . ($\pi \times 5.25^2 \times 1.95$)

ACTIVITY TWO

- $21\,951\,384 \text{ mm}^3$. ($184 \times 399 \times 299$)
 - $22\,450\,386 \text{ mm}^3$. ($186 \times 401 \times 301$)
- $1\,450$ tonnes.
($2\,500 \times 100 \times 10 \times 0.58 = 1\,450\,000 \text{ kg} = 1\,450$ tonnes)
 - $3\,219 \text{ m}^3$.
($0.185 \times 0.4 \times 0.3 \times 100 \times 2\,500 \times 0.58 = 3\,219 \text{ m}^3$)

Page 16

Cylinder Collection

ACTIVITY

1.

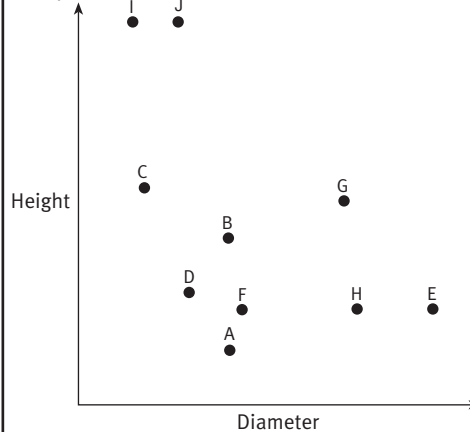

2.

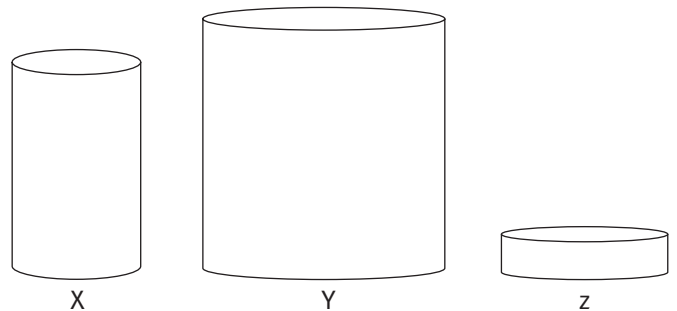

- In the top right-hand area of the graph

Page 17

Round the Bend

ACTIVITY ONE

- Predictions will vary. A likely prediction is that any difference will be too small to notice.
 - 0.80 m . (Circumference of Earth = $40\,000\,000 \text{ m}$, therefore radius = $40\,000\,000 \div 2\pi = 6\,366\,197.72 \text{ m}$. Length of rope with 5 m added = $40\,000\,005 \text{ m}$, therefore radius = $6\,366\,198.52$. Difference in radius = $6\,366\,198.52 - 6\,366\,197.72 = 0.80 \text{ m}$.)

2. 12.54 m. (To be 2 m off the ground, the radius would need to be $6\,366\,197.72 + 2$. So the length of the rope would be $6\,366\,199.72 \times 2\pi = 40\,000\,012.54$ m.)

ACTIVITY TWO

1. Practical activity. Your graph should look similar to this:

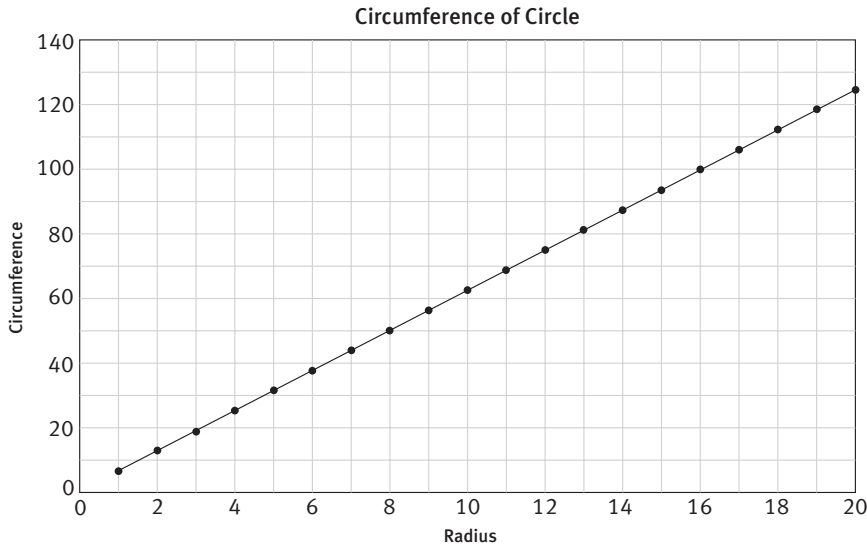

2. Each time you add 1 unit to the radius, the circumference increases by 2π units (approximately 6.28 units). This is true no matter how great the radius is.

Pages 18–19 On the Right Track

ACTIVITY

1. 100 m. See the diagram:

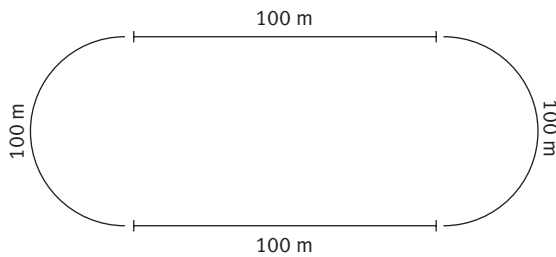

2. 63.66 m. ($200 \div \pi$)
 3. a.–b. Practical activities
 4. a. 432.98 m. ($200 + 74.16 \times \pi$)
 b. 33.0 m. ($433.0 - 400$)

5. Practical activity. In the 200 m event, the runner in the inside lane would start at the point where the first curve and the second straight meet; the runner in the outside lane would start 16.5 curved metres in front of this. In the 400 m event, the runner in the inside lane would start on the finishing line; the runner in the outside lane would start 33.0 curved metres in front of this.

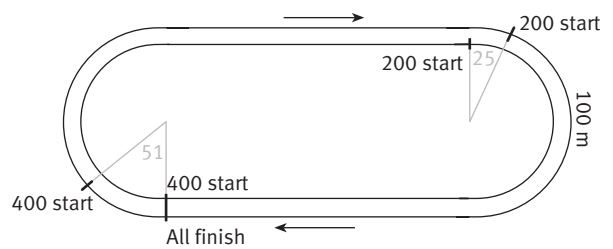

6. $9\,549 \text{ m}^2$ (slightly less than a hectare).
 (Area of rectangle + area of circle = $100 \times 63.66 + \pi \times 31.83^2$
 $= 6\,366 + 3\,183$
 $= 9\,549$)
7. a. Yes. The diameter of a circle with a circumference of 400 m is 127.3 m. ($400 \div \pi$). Its radius is $127.3 \div 2 = 63.65$. Its area = $\pi \times 63.65^2 = 12\,728 \text{ m}^2$, which is greater than the $9\,549 \text{ m}^2$ for the other track.
- b. Possible comparisons include:
- The area of the circle is about $\frac{1}{3}$ (33%) greater than the area of the oval ($\frac{12\,728}{9\,549} = 1.33 = 133\%$)
 - The area of the oval is about $\frac{3}{4}$ (75%) of the area of the circle ($\frac{9\,549}{12\,728} = 0.75 = 75\%$)
 - The ratio of the area of the circle to the oval is approximately 4:3.

8. a. Practical activity
- b. 437.7 m. (The diameter of the outside track of the circle is $127.32 + 12 = 139.32$ m. The circumference is therefore $\pi \times 139.32 = 437.7$ m.)
9. The starting positions will be 16.5 and 33.0 curved metres ahead of the positions for the runner in the inside lane.

Pages 20–21 Gumboot Games

ACTIVITY ONE

1. Matiu, Jackson, Mere, Mark, Carey, Beth, David, Simone
2. a. $3\,120\text{ cm}^3$
b. $3\,120\text{ g}$ and 3.12 kg
3. 19 bottles. (Tim's 18.42 m throw wins him the equivalent of 9 gumboots full of soft drink. $9 \times 3.12 = 28.08\text{ L}$, which is nineteen 1.5L bottles, when rounded up.)

ACTIVITY TWO

1. a. Answers will vary.
b. Gumboot = 0.063
Brick = 0.016
Cricket ball = 0.635
Cowpat = 0.318
Rolling pin = 0.050
c. Cricket ball
d. Answers will vary. A likely theory is that the heavier the object, the lower the rate (or the lighter the object, the higher the rate).
2. a. Practical activity
b. Answers will vary. The experimental data should generally show that the heavier the object, the lower the rate. There are, however, other factors at work:
 - the aerodynamics of the object (a cricket ball will have a better throwing rate than a cube of exactly the same mass)
 - the density of the object (a glass marble will have a better throwing rate than a polystyrene ball of exactly the same size).

INVESTIGATION

Results will vary, but your investigation should explore the factors mentioned in the answer to 2b (above).

Pages 22–23 Hot Pots

ACTIVITY ONE

The roster could look like this:

Roster			
Time	Activity	Students	Adult
0800	Start work		
0930	Kiln ready		
1000	Light fire	1 and 2	Mrs Jackson
1115		3 and 4	
1230	Lunch	5 and 6	
1320	Lunch finishes		
1345		7 and 8	
1500	School finishes	9 and 10	
1600	Afternoon tea		
1615		11 and 12	
1620	Afternoon tea finishes		
1700	Softball		
1730		13 and 14	
1750	Softball ends		
1830	Dinner		
1845		15 and 16	
1900			1
1915	Dinner ends		
2000		17 and 18	
2030	Video		2
2115		19 and 20	
2200			3
2222	Video ends		
2230		21 and 22	
2245	Lights out		
2330			4
2345		23 and 24	
0100		25 and 26	5
0130			
0215	Student roster finishes		
0230	Adult supervisors finish		
0715	Breakfast		
0815	Rooms sorted		

N.B. The softball could be during any 50 minute time slot between afternoon tea and dinner.

ACTIVITY TWO

1.

Time	Stakes burnt per hour	Total stakes burnt
1000		
1100	80	80
1200	60	140
1300	40	180
1400	40	220
1500	40	260
1600	40	300
1700	40	340
1800	40	380
1900	24	404
2000	15	419
2100	9	428
2200	6	434
2300	4	438
2400	3	441
0000	2	443
0100	2	445
0200	2	447

2. 2 stakes; because we are taking 60% of 2, then rounding the result, which takes the number back up to 2 each time

3.



4. Between 1800 and 1900 hours

5. a. When the rate is greatest, the graph is steepest.
 b. When the rate is least, the graph is most nearly horizontal.

ACTIVITY

1. Practical activity
2. Answers will vary.

INVESTIGATION

Answers will vary. You should discover that the wind chill factor can never make something colder than the air temperature. (No matter how severe the wind, water will not freeze if the air temperature is above 0°C.) What the wind chill factor does do is greatly speed up the cooling process. This means that hypothermia can set in much more rapidly, before a person has had time to realise the danger. If the conditions make hypothermia a risk, you should wear warm clothes (including a hat), keep dry, and if possible, keep out of the wind.

Teachers' Notes

Overview

Measurement: Book Two

Title	Content	Page in students' book	Page in teachers' book
Light and Sound	Measuring speed, using distance and time	1	10
Plentiful Plankton	Working with millimetres, micrometres, and ratios	2–3	11
Fat in Foods	Solving problems involving ratios and units of mass	4–5	12
Television Views	Using ratio and/or scale drawing to find unknown lengths	6–7	14
Hot Dogs	Using ratio to compare surface area and volume	8–9	15
Pounamu Pendants	Estimating area and using percentages	10	16
Time and Tide	Interpreting cyclical graphs	11	17
The Big Drip	Working with length, area, and volume	12–13	19
Colossal Kiwifruit	Working with circles, area, and volume	14–15	20
Cylinder Collection	Comparing dimensions graphically	16	21
Round the Bend	Exploring the π relationship	17	22
On the Right Track	Working with circles and drawing to scale	18–19	23
Gumboot Games	Working with distance, volume, mass, and rates of change	20–21	24
Hot Pots	Performing calculations, using 24 hour time	22–23	26
Chilling Out	Constructing and using scales	24	27



Achievement Objectives

- carry out measuring tasks involving reading scales to the nearest gradation (Measurement, level 4)
- interpret and use information about rates presented in a variety of ways, for example, graphically, numerically, or in tables (Measurement, level 5)
- collect appropriate data (Statistics, Level 4)
- devise and use problem-solving strategies to explore situations mathematically (Mathematical Processes, problem solving, level 4)

ACTIVITY

In this practical outdoor experiment, the students measure the time that elapses between observing an event and hearing the sound associated with it. By also measuring the distance involved, they calculate an approximate value for the speed of sound.

Introduce this activity by discussing with your students the delay between sight and sound. Most will know that we see lightning before we hear the thunder; they may also have seen the smoke from a starting pistol before hearing the “crack” or have seen a jet crossing above before hearing the sound of its engines. They may know that mountaineers and skiers can see an avalanche before they hear its roar. Because light travels extremely fast, we see things the moment they happen, but because sound travels relatively slowly, we hear things only after a delay. Another familiar phenomenon that demonstrates the relatively slow speed of sound is echo. Most students will have been in an environment where they have made a noise and then heard a distinct echo a second or two later. The delay is the time it takes for their voice to reach a reflecting surface and return to them.

Sound travels approximately 1 kilometre in 3 seconds, so it takes less than a second to travel 300 metres. The students will find it difficult to measure an interval of much less than a second, so the experiment in question 1 should be carried out over a distance of at least 300 metres. It may be best to measure out a suitable distance beforehand and to assign one or two people to be block slappers. This will mean that other members of the class can be at your end of the course, in small groups, sharing the timing and the recording. You may want to agree on signals so that you can communicate with those at the far end, or you may wish to communicate using cellphone text messages. The students could record their timings on a standardised chart.

Question 2 can be done back in the classroom. If the students pool all their results and average them, they should get a fairly accurate timing for sound to travel the measured distance. They should then be able to use this to find a good approximation for the speed of sound in metres per second.

In question 3, the students are asked to think about how they might improve this experiment.

They may suggest:

- Making a louder sound. The ideal is a starting pistol.
- Measuring out a longer distance. As long as there is a clear line of sight and a sound that is loud enough to carry, the greater the distance, the better.
- Waiting for a still day. Windy conditions make it difficult to hear the sound and distort the times.

Question 4 is a personal or pair investigation into how the speed of light was first measured. For a long time, it was believed that light was instantaneous. Galileo tried to time a light signal as it travelled from one hilltop to another, but no matter how far apart the signal and the observer were, there was no measurable delay. It was the Danish astronomer Ole Roemer who first realised that light did indeed have speed. Investigating the eclipses of Jupiter’s moons, he observed that they sometimes came ahead or behind schedule. He correctly deduced that the cause must be the speed of light and came up with a surprisingly good estimate of that speed. Students who elect to investigate this story could present their findings to the rest of the class as a talk, computer presentation, or wall chart.

You could also challenge your students to investigate the speed of sound through other media, such as the pipe rail of a long fence, a disused railway line, or water.

Try to ensure that by the end of this activity, all students have learned that sound takes approximately 3 seconds to travel 1 kilometre. The next time they are in a thunderstorm, they can time the interval between the flash and the sound and know how far away the lightning is.

CROSS-CURRICULAR LINKS

Science

This activity could be part of a unit on light and sound.

Achievement Objective

- investigate and offer explanations for commonly experienced physical phenomena and compare their ideas with scientific ideas, (Making Sense of the Physical World, level 4)

Pages 2–3

Plentiful Plankton

Achievement Objectives

- carry out measuring tasks involving reading scales to the nearest gradation (Measurement, level 4)
- interpret and use information about rates presented in a variety of ways, for example, graphically, numerically, or in tables (Measurement, level 5)
- make sensible estimates and check the reasonableness of answers (Number, level 4)
- round numbers sensibly (Number, level 5)

ACTIVITY

In this activity, students calculate the actual size of microscopic creatures from drawings that are highly magnified. Although the words are not used in the students' book, the activity is about enlargement and scale factor as much as it is about measurement.

In questions 1 and 2, the students need to measure the length of the enlarged zooplankton and then divide by the scale factor to get the actual length. They should be able to do this measurement accurate to the nearest millimetre. If they are getting different lengths, you may need to check that they know how to measure the distance between two lines (as distinct from measuring the distance between two points). They must measure at right angles to the lines so that they find the shortest distance between them. Dividing by the scale factor is simply reversing the enlargement process. In question 3, they need to divide the scale length by the actual length to get the magnification.

In each question, the students are asked for lengths in millimetres and micrometres. You could give them this table showing the tidy way in which the metric system deals with the full range of (length) measurement from very large to extremely small:

1 000 picometres	=	1 nanometre	(1 billionth of a metre)	(10^{-9} metres)
1 000 nanometres	=	1 micrometre	(1 millionth of a metre)	(10^{-6} metres)
1 000 micrometres	=	1 millimetre	(1 thousandth of metre)	(10^{-3} metres)
1 000 millimetres	=	1 metre	The base unit	(10^0 metres)
1 000 metres	=	1 kilometre	(1 000 metres)	(10^3 metres)

Some students may wish to find out the names for the in-between units. They may also want to find out why, in New Zealand, we do not make much use of terms such as hectometre (100 metres). Most of these units are unnecessary because the measurements can be conveniently expressed using more basic units. Sometimes one of them is used in a particular context for historical reasons or because it is the ideal unit. For example, you will find the centilitre unit (1 hundredth of a litre) used on all wine bottles, and the hectolitre unit (100 litres) is sometimes used when discussing wine production. Students may also be interested in trying to find out why it is that the US (unlike almost every other country in the world) does not use the metric system. There are a number of informative websites on this theme, including this National Institute of Standards and Technology site: <http://ts.nist.gov/ts/htdocs/200/202/1c1136a.htm>

CROSS-CURRICULAR LINKS

Science

This activity could lead into a study of the tiny animals around us (such as dust mites) that we are usually unaware of.

Achievement Objectives

- investigate and describe special features of animals or plants which help survival into the next generation (Making Sense of the Living World, level 4)
- investigate, and classify in broad terms, the living world at a microscopic level (Making Sense of the Living World, level 5)

Pages 4–5

Fat in Foods

Achievement Objectives

- carry out measuring tasks involving reading scales to the nearest gradation (Measurement, level 4)
- interpret and use information about rates presented in a variety of ways, for example, graphically, numerically, or in tables (Measurement, level 5)
- share quantities in given ratios (Number, level 5)
- make statements about implications and possible actions consistent with the results of a statistical investigation (Statistics, level 4)

Practically any dietary issue is controversial. The role of fat in the diet is as controversial as any. You need to be careful about how discussion on this topic develops and what statements you make. In your class, you may have obese students and potential anorexics. You may have your own strongly held but controversial theories on diet and nutrition; you should make sure that you don't teach these as fact. The overwhelming evidence is, however, that obesity is a major threat to our young people, and we need to ensure that they are aware of the importance of a healthy, balanced diet and lifestyle.

ACTIVITY

In question 1, the students learn how to compare the amount of fat in different foods by converting the given information into a standardised measurement: grams of food per gram of fat. This is a question of ratios, but in each case, the ratio is expressed in the form $x : 1$ for ease of comparison.

You should discuss with your students the approximate nature of the data in this activity. All measurements have been rounded to the nearest gram, and your students should do the same with the results of their calculations. In practice, the fat content of many of the items listed will vary considerably. You could suggest that your students do the calculations without a calculator. They should be able to do most of them easily in their heads.

Once they have completed their table, the students have to decide which types of food have the highest and lowest proportions of fat. They could structure the task by grouping all the given items into three categories: little or no fat, moderate fat, and high fat. You could also ask them to add 5 more items to each category, based on what they think the fat content of those items would be, and then to check that they have correctly assessed them.

In question 2, the students are asked to find the fat content of a muffin, based on the amount of butter used, and then to complete an equivalence task. The unit used in each case is the one that is most appropriate for that food. Again, it is expected that the answers will be very approximate, and the students should not need calculators to work them out.

Question 3 asks the students to make up some sample lists of foods that Jeremy could eat, keeping within the dietician's guidelines and using the information from page 4. They should soon see that combinations such as a hamburger and large fries contain the recommended daily maximum or very close to it.

INVESTIGATION

For this investigation, the students need to collect nutritional information from the packaging of prepared foods and then collate and analyse it. The information panels use standard headings, so it is a simple matter to enter the information into a computer spreadsheet. Once the students have done this, they can experiment with different kinds of graph until they find the best way of comparing the fat (and perhaps the carbohydrate and sodium) content of the various foods. They should consider:

- graphs that display a single piece of information (for example, total fat content per 100 grams) for 20 different foods
- separate graphs for each of 20 foods, each displaying multiple information.

Despite the wide variety of graph types available with computer spreadsheets, bar graphs are still one of the most suitable types of graph in this situation.

The students could create a wall display using their data and graphs. When preparing displays, they should include the conclusions they have reached from their investigations. Some may even decide to make changes to their own eating habits as a result!

CROSS-CURRICULAR LINKS

This activity could form part of a much larger unit on healthy eating.

The National Heart Foundation's website has information about fat and carbohydrates in foods (see www.nhf.org.nz). The Foundation's Fat Kit, which is suitable for school use, is a useful resource for demonstrating the type and amount of fat in commonly eaten takeaways. Included in the kit are teaching notes on healthy takeaway meals and alternatives to commercial takeaway choices.

It is sometimes alleged that fast food franchises are secretive about the content of their foods, but students will find that they have very detailed nutritional information on their websites, for example:

www.mcdonalds.com/countries/usa/food/nutrition/menuitems/index.jsp

www.yum.com/nutrition/kfc/nutrition_short.asp

Achievement Objectives

Science

- investigate how knowledge of science and technology is used by people in their everyday life (Making Sense of the Nature of Science and its Relationship to Technology, level 5)

Health and Physical Education

- access and use information to make and action safe choices in a range of contexts (Personal Health and Physical Development, level 4)

Achievement Objective

- calculate perimeters of circles, rectangles, and triangles, areas of rectangles, and volumes of cuboids from measurements of length (Measurement, level 4)
- enlarge and reduce a 2-dimensional shape and identify the invariant properties (Geometry, level 4)
- recognise when 2 shapes are similar, find the scale factor, and use this to find an unknown dimension (Geometry, level 5)
- share quantities in given ratios (Number, level 5)

ACTIVITY ONE

This activity is about using ratio to find the missing dimensions of similar shapes.

The key concepts here are:

- *Similarity*. In normal usage, this word means that two things resemble each other, usually in some vague and unspecified way. In mathematics, it means that two shapes are identical in all respects except for size (in other words, one is an enlarged version of the other).
- *Ratio*. When two figures are similar, a comparison of *any* pair of *corresponding* sides will give the same ratio (in other words, the scale factor of the enlargement). Corresponding sides are “matching” sides. To find the ratio for two similar figures, you must first find two corresponding sides for which the measurements are known. The diagram illustrates this principle:

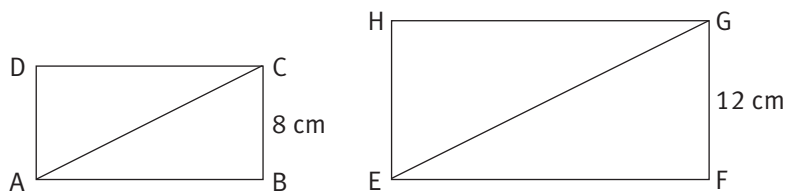

$$EF/AB = GF/CB = FG/BC = EG/AC = FH/BD = 12/8 = 1\frac{1}{2} = 1.5$$

In other words, every length in the second rectangle (whether drawn in or not) is 1.5 times the corresponding length in the first rectangle. Working in reverse, every length in the first rectangle is $\frac{2}{3}$ ($\frac{8}{12}$) of the length in the second rectangle.

Note that there are many other internal comparisons that can also be made. For the above example, these include: $AD/DC = EH/HG$ and $AC/AB = EG/EF$

Such comparisons can often be used to help solve problems, but they do not give the scale factor.

The diagrams in questions 2 and 3 have been drawn to scale, so students who are unfamiliar with ratio may solve the questions by measurement. However, if they use this method, they will learn nothing new from the activity.

Two of the questions, 2d and 3b ii, involve working with the lengths of diagonals, and it may look as if Pythagoras' theorem is needed, but it is not. The students can use ratio to solve question 2d by comparing the length of the diagonal (20) with the length of the diagonal in the example at the top of the page (59) to get the ratio $\frac{20}{59} = 0.339$. The width and height of the screen in question 2d can now be found by multiplying the width and height in the example (47.2 and 35.4) by 0.339. Question 3b ii can be solved mentally by noting that the diagonal (36.8) is exactly twice the length of the diagonal in the example at the start of question 3 (18.4). So the width and height of 3b ii are twice those dimensions in the example.

ACTIVITY TWO

In this activity, the students discover that the on-screen dimensions of a photograph grow when the screen resolution is reduced and shrink when the screen resolution is increased. This is an example of an *inverse* relationship (one variable is increased when another is decreased). Discuss other examples of inverse relationships with your class, for example, the speed–time relationship (when speed increases, time decreases).

When doing tasks of this kind, the students should ask themselves whether they should get an increase or a decrease. If they expect an increase, their ratio should have the larger number on top. If they expect a decrease, their ratio should have the smaller number on top. At the original resolution of 1 024 by 768, the photo is 15 centimetres long. If the resolution is reduced to 640 by 480, the screen size of the photo is increased (as explained by the text), so the ratio is $1\,024/640$ (or $768/480$), and the screen length of the photo becomes $15 \times 1\,024/640 = 24$ centimetres (the original length multiplied by the scale factor).

CROSS-CURRICULAR LINKS

This activity could be part of a unit on computers or consumer electronics.

Science

Achievement Objective

- investigate how physical devices or systems can be used to perform specified functions (Making Sense of the Physical World, level 5)

Technology

Achievement Objective

- investigate and explain the use and operation of a range of technologies in everyday use, such as in communications (Technological Knowledge and Understanding, level 4)

Pages 8–9

Hot Dogs

Achievement Objectives

- share quantities in given ratios (Number, level 5)
- find perimeters, areas, and volumes of everyday objects (including irregular and composite shapes), and state the precision (limits) of the answer (Measurement, level 5)
- find, and use with justification, a mathematical model as a problem-solving strategy (Mathematical Processes, problem solving, level 4)

ACTIVITY

In this activity, the students investigate the relationship between body size and surface area, using ratio. According to the suggested learning experiences for Number, students working at level 5 could be:

- exploring the use of ratio in everyday contexts
- developing meaning for ratio by comparing two like quantities
- investigating equivalent ratios
- recording ratios as a/b and $a : b$.

They will have all of these experiences as they work through this activity.

When doing questions 1 and 2, the students need to make sure that they count all the faces. They may find that the most systematic way of doing this is to consider each of the 6 possible views in turn (left, right, up, down, front, and back). They then put the numbers in a table and calculate the ratio of surface area to volume. For ease of comparison, they are asked to put the ratio in the form $x : 1$ (as in Fat in Foods, pages 4–5 of the students' book).

The students may have trouble seeing how to get from $34 : 8$ to $4.25 : 1$. To achieve this, they must divide both sides of the ratio by 8 (because $8 \div 8 = 1$). This division makes use of the principle of equivalent ratios, which says that $2 : 3 = 4 : 6 = 18 : 27 = 1 : 1.5 = 200 : 300$, and so on. This is the principle of equivalent fractions, slightly disguised. As well as helping your students work with these ratios, you may also need to help them interpret the meaning of the ratios they have calculated.

In question 2d–e, the students discuss the relationship between surface area and volume. They should be able to see that as the volume increases, so does the surface area, though not in a fixed ratio (because the shape of dogs varies greatly). This means that a small dog has a proportionally greater area of skin through which to gain (or lose) heat and is therefore more at the mercy of external conditions. Compare the vulnerability of a human baby.

INVESTIGATION

Hypothermia is the result of excessive heat loss through the skin, the reverse of the overheating problem that is the focus of questions 1 and 2. Hypothermia is often the cause of death in water accidents, rather than drowning (think of the *Titanic*). It is also a threat for unprepared trampers and climbers in the New Zealand outdoors. The last activity in this book, Chilling Out (page 24 of the students' book), is also relevant here.

Information about hypothermia can be found on the Internet, including these sites:

www.princeton.edu/~oa/safety/hypocold.shtml

www.hypothermia.org

CROSS-CURRICULAR LINKS

Health and Physical Education

This activity could form part of a unit on hypothermia or safety in the outdoors.

Achievement Objectives

- access and use information to make and action safe choices in a range of contexts (Personal Health and Physical Development, level 4)
- investigate and practise safety procedures and strategies to minimise risk and to manage risk situations (Personal Health and Physical Development, level 5)

Science

This activity could be used in conjunction with a unit based around Building Science Concepts Book 46, *Keeping Warm* and Book 47, *Insulation*.

Achievement Objective

- investigate and describe structural, physiological, and behavioural adaptations which ensure the survival of animals and flowering plants in their environment, *e.g.*, the organ systems which animals use to locate, catch (or harvest), eat, digest, transport, and use food; territoriality; social behaviour; photosynthesis, osmosis; transpiration (Making Sense of the Living World, level 5)

Achievement Objectives

- find perimeters, areas, and volumes of everyday objects (including irregular and composite shapes), and state the precision (limits) of the answer (Measurement, level 5)
- express one quantity as a percentage of another (Number, level 5)

ACTIVITY

This activity asks the students to estimate the percentage of a rectangular shape that remains after it has been carved to make a pendant. The estimate is based on a 2-D illustration of a 3-D object.

When doing question 1, the students need to follow these steps:

- Find the area of the shaded rectangle behind the carved pendant.
- Count the squares and part squares covered by the pendant to get an estimate of the total area it covers.
- Divide the area of the pendant by the area of the rectangle.
- Express this result as a percentage.

The standard method for estimating area by counting squares is to count every square that is at least half-covered by the object. A second method is to visually estimate what part of each square is covered by the object, to the nearest tenth (for example, 0.3), and then to add these parts along with the wholes. You could ask your students to try both methods (the second being good for practice at adding decimals) and see whether they think one gives a better result than the other. For a similar task, see **Activity One** of *The Big Drip* (pages 12–13 of the students' book).

The students' estimates should fall within the range given in the Answers.

Question 2 asks the students to design a pendant on square grid paper, with the design covering 50 percent of the rectangular area that encloses it. This activity encourages creative as well as mathematical skills. The finished designs could be coloured and displayed or used as the basis for making clay or play dough pendants.

CROSS-CURRICULAR LINKS

This activity could be used as part of a study of Māori arts and crafts. Students could investigate the special significance of pounamu, the way in which carvers in former times made pendants, and the way in which present-day carvers make them.

Achievement Objectives

Social Studies

- demonstrate knowledge and understandings of why and how individuals and groups pass on and sustain their culture and heritage (Culture and Heritage, level 4)

Arts and Crafts

- investigate the purposes of objects and images in past and present cultures and identify contexts in which they were or are made, viewed, and valued (Understanding the Visual Arts in Context, level 4)

Achievement Objectives

- read and construct a variety of scales, timetables, and charts (Measurement, level 4)
- perform calculations with time, including 24-hour clock times (Measurement, level 4)
- interpret and use information about rates presented in a variety of ways, for example, graphically, numerically, or in tables (Measurement, level 5)

ACTIVITY

This may be the first time that your students have met a cyclical time-series graph. If your school is near the coast, you may have students who love fishing and who understand the way tides work even if they aren't sure about what causes them. Because of New Zealand's coastal nature, most students will have had at least some first-hand experience of tides. You can build on this.

Tides are caused by the gravitational pull of our moon on the oceans. As the Moon orbits the Earth, we say that it rises and sets. Where the Moon is directly above, the oceans below experience a high tide (and, interestingly, so do the oceans on the opposite side of the Earth). The Moon orbits the Earth once approximately every 25 hours, so there are 2 high tides and 2 low tides within this time. Neap and spring tides are caused when the Sun also affects the tides and gives greater gravitational pull to the Moon (spring tides) or reduces the effect of that pull (neap tides).

Questions 1 and 2 ask the students to read values directly from the graph, but question 3 involves some interpretation. The steeper the curve, the greater the rate of change (in this case, of tide level). Relate this to your students' personal experiences of tides. If they have ever made sandcastles on the beach at the high tide point, they will know that there is a period when it is hard to know if the tide is coming in any further or not. This period (represented by the crest of the peaks on the graph) may last for 10 or 15 minutes. During this time, their construction is under threat. And then they realise that all danger has passed. The tide is now on its way out.

Discuss with your students how the slope of the graph changes as the tide rises and falls. Use the opportunity to talk in terms of positive and negative slope (a positive slope goes uphill as your eyes scan it from left to right, and a negative slope goes downhill). In this case, a positive slope represents an incoming tide. Ask your students how they could describe the slope of the graph at its peak. They should be able to recognise that, at this point, the slope is neither positive nor negative. The slope is therefore 0, the only number that is neither positive nor negative.

In question 5, the students need to make use of the fact that the graph is cyclical to predict when the next high tide will be. The key to the prediction is recognising that the *period* of the graph (the time taken for one complete cycle) is very nearly 12:30 hours. This means that if it is high tide at 5 a.m. this morning, the next high tide will be at approximately $05:00 + 12:30 = 17:30$ hours (5.30 p.m.) this evening.

Let your students discuss question 6 for some time if necessary and avoid confirming the correct answer the moment someone suggests it (if they do!). Let them think of possibilities and then challenge them to think of reasons for retaining or discarding each of them. Hopefully someone will come up with the very important idea that tide tables are always predictive (published in advance). This means that, whatever the cause, it was able to be predicted with complete accuracy days or even weeks in advance. This rules out tsunami, cyclones, earthquakes, and the like. We do not know when these events will hit, nor do we know what the exact effects will be. The answer is not that something dramatic and unusual has happened to the *tides* but that something has happened to the *time*. Because of the introduction of daylight saving, part of the graph has been translated 1 hour to the right. The odd break in the curve reflects the human manipulation of time.

OceanFun Publishing, who created and supplied the graphic in the students' book have a website:

www.ofu.co.nz/graph/tides.htm Students can use this site to find the tides for each day at many different places around the New Zealand coastline.

CROSS-CURRICULAR LINKS

Science

Students could investigate the relationship between the Sun, the Earth, and the Moon, using the Ministry of Education's digital learning object Day and Night, which can be found at

www.tki.org.nz/r/science/day_night/index_e.php

Students could also investigate how Māori used the phases of the Moon as a guide for planting foods.

Achievement Objective

- investigate and use models which explain the changing spatial relationships of the Earth, its moon, and the Sun, and the way different cultures have used these patterns to describe and measure time, and position (Making Sense of Planet Earth and Beyond, level 4)

Achievement Objectives

- carry out measuring tasks involving reading scales to the nearest gradation (Measurement, level 4)
- find perimeters, areas, and volumes of everyday objects (including irregular and composite shapes) and state the precision (limits) of the answer (Measurement, level 5)
- make sensible estimates and check the reasonableness of answers (Number, level 4)
- solve practical problems involving decimals and percentages (Number, level 5)

In these activities, the students work with area and volume based on scale diagrams. They also use percentages, ratios, and rates.

ACTIVITY ONE

Questions 1 and 2 are similar to the questions in Pounamu Pendants (page 10 of the students' book). The students estimate the area of a composite shape by counting squares. Each square conveniently represents 1 square metre. Two ways of dealing with part squares are discussed in the notes for Pounamu Pendants. Question 1 asks the students to exclude the area of the garage in their calculations. Some may not notice this instruction.

In question 3, the students use the areas they calculated in questions 1 and 2 to work out a percentage and a ratio. Before they enter values into their calculators, they should note that, very roughly, half the house (excluding the garage) has been flooded, so they should get a result that is somewhere around 50 percent. If they then divide the total area by the flooded area and get an answer such as 240 percent, they should realise that they have made a mistake.

Question 3b is not simply a matter of converting a percentage (question 3a) into a ratio. In this case, the students are comparing the flooded area to the non-flooded area, *not* the total area. Encourage them to look for a simple ratio (as in the Answers) that is a good approximation.

ACTIVITY TWO

When doing question 1, the students should convert all measurements to metres and give their answers in square metres and cubic metres. This will avoid large numbers of zeros and reduce the risk of putting a decimal point in the wrong place.

Question 2 is best done using hours rather than minutes. The first step is to work out how much water would enter the room in an hour. The next step is to divide the volume of the room by the volume of water that would enter in an hour. Some students may need to be talked through this relationship.

The students can solve question 3 by taking the area of the room and subtracting the area of each of the fittings. Alternatively, they can divide the irregular shape of the vinyl into various rectangles, find their areas, and then add them together.

In question 4, the students measure their own bathroom and draw a plan of it. They could make their measurements accurate to the nearest centimetre. They will need to use a suitable scale: 10 centimetres to 1 metre may be suitable for a small bathroom, 5 centimetres to 1 metre for a larger bathroom. They should write down their estimates and calculations in an orderly way so that others can understand what they are doing.

Achievement Objectives

- find perimeters, areas, and volumes of everyday objects (including irregular and composite shapes) and state the precision (limits) of the answer (Measurement, level 5)
- solve practical problems involving decimals and percentages (Number, level 5)
- make sensible estimates and check the reasonableness of answers (Number, level 4)
- round numbers sensibly (Number, level 5)

ACTIVITY ONE

In this activity, the students work with the circumference and area of circles and the volume and weight of boxes, all in a kiwifruit context. They are asked to round numbers using significant figures and to work with specified limits of accuracy. This may be the first time that your students have come across the need for these skills.

Of all the methods of rounding, rounding by *significant figures* is perhaps the most useful. It is also the most difficult to fully understand, mainly because zeros are sometimes significant and sometimes not.

To round a number to 3 significant figures: begin at the left-hand end of the number and read along to the right until you come to the first *non-zero digit*. This is the first significant figure. The next two digits (even if they are zeros) are the second and third significant figures. Remove all the remaining digits (after the third significant figure), but before doing so, check the fourth digit. If it is 5 or more, add 1 to the third digit. Replace any digits between the third significant figure and the decimal point with zeros. (In the examples below, these zeros are italicised.) In each case, the bold digits are the first 3 significant figures.

Examples:

- **3.14**1592654 = 3.14 (3 sf)
- 0.00**523**142 = 0.00523 (3 sf)
- **904** 618 342 = 905 *000 000* (3 sf)
- 0.0000**713**8922 = 0.0000714 (3 sf)
- **11 392** = 11 *400* (3 sf)
- **47.9877** = 48.0 (3 sf)
- **15 001 784** = 15 *000 000* (3 sf)

For many students, the hardest part of the rounding process is understanding the role of the zeros of the kind that have been italicised here. They are place holders and ensure that the original number is rounded, not reduced or increased by a factor of 10. Note that, apart from the zero that is usually put in front of a decimal point when the number is greater than -1 and less than 1, zeros are never optional when rounding by significant figures. They are either necessary or wrong.

When doing the various parts of this activity, the students should set out the processes on paper but do all the calculations with a calculator. They should also use the π key on their calculator rather than the approximation 3.14. If they don't do this, their answers will be slightly different from those in this book.

When doing question 3, some students may forget that the kiwifruit has 2 sides and needs 2 coats of paint. For each part, the students need to find the area, multiply by 2 (coats), multiply by 2 (sides) if appropriate, and then divide by 12 to get the amount of paint needed.

ACTIVITY TWO

Before the students start this activity, you should specifically explain the *limits of accuracy* concept. It is not something that they are likely to be able to work out for themselves.

The basic idea is that no measurement is exact. While measurements can be as precise as our instruments permit, they can never be perfect. For example, a skilled cabinetmaker is able to measure and cut materials to the nearest millimetre but no more. You can't read tapes and rules to the nearest tenth of a millimetre. This means that when carpenters say a piece of wood is 422 millimetres long, they mean that it is closer to 422 than to 421 or 423. 422 millimetres therefore includes every measurement from 421.5 up to, but not including, 422.5. This is normally written $421.5 \leq \text{length} < 422.5$. Expressed in another way, if something is measured accurate to the nearest centimetre (or metre, kilogram, or hectare), then the measurement includes all possible measurements up to half a centimetre (or metre, kilogram, or hectare) either side of it.

Question 1 defines the limits of accuracy to be 1 millimetre. This means that each of the measurements can be up to 1 millimetre shorter or longer than the given length. This means that two calculations are required. In the first, the students take the least possible length, breadth, and height for each pack and multiply them together to get the minimum possible volume. In the second, they use the maximum possible dimensions to get the maximum possible volume.

Question 2 involves percentages, volume, and mass. The students need to read the question carefully or they will find the total volume and mass of the shipment, not the 58 percent that is exported in 10-kilogram packs. They also need to notice that 1 000 kilograms is 1 tonne.

CROSS-CURRICULAR LINKS

Colossal Kiwifruit could be part of a unit about the history and economics of a farming area. The students could investigate how the area was first cleared for farming livestock and the factors that later led to it being transformed by another commodity (such as kiwifruit, grapes, olives, or timber).

Achievement Objectives

Social Studies

- demonstrate knowledge and understandings of how and why people view and use resources differently and the consequences of this (Resources and Economic Activities, level 4)

Technology

- explore and discuss the impacts over time on the local and wider environments and society of some specific technology (Technology and Society, level 4)

Achievement Objectives

- interpret and use information about rates presented in a variety of ways, for example, graphically, numerically, or in tables (Measurement, level 5)
- sketch and interpret graphs on whole number grids which represent simple everyday situations (Algebra, level 4)

ACTIVITY

In this activity, students visually interpret the relationship between the height, diameter, and volume of a collection of cylinders. They graph the relationship and then use the information to draw a conclusion.

You could introduce this activity by bringing a collection of cylinders to the classroom and asking the students to sort them first by height, then by diameter, and then (on a large table) by both height and diameter. They could then measure each cylinder and accurately plot them on a graph similar to the one in the students' book but with the axes marked in centimetres.

In question 1, there are no units marked on the axes, so the students need to compare each cylinder with G, which is already plotted. Is it thinner or fatter than G, shorter or taller than G? Points are then plotted for the other cylinders by comparing them with ones already on the graph.

It is possible that some students may realise that they can be quite precise about the position of each point by using the method in this diagram.

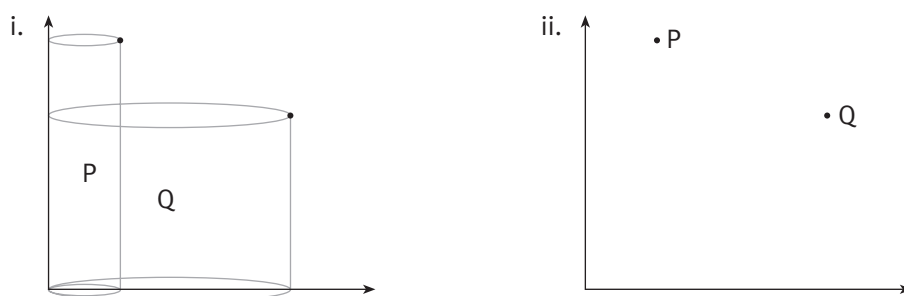

Similarly, they could measure the height and diameter of each cylinder in the illustration in their book and use these measurements to mark the location of each point on the graph. However, this method removes the need to make comparisons, which is the main point of the activity.

In question 2, the students work in reverse, from plotted point to cylinder, and in question 3, they show they understand the finished graph by explaining where to look for the cylinders with the greatest volume. They should be able to justify their answer.

Achievement Objectives

- calculate perimeters of circles, rectangles, and triangles, areas of rectangles, and volumes of cuboids from measurements of length (Measurement, level 4)
- make conjectures in a mathematical context (Mathematical Processes, developing logic and reasoning, level 4)
- generalise mathematical ideas and conjectures (Mathematical Processes, developing logic and reasoning, level 4)

ACTIVITY ONE

This activity explores how a small increase in circumference can make a surprising difference to the radius (or diameter) of a circle. The students should not attempt Round the Bend until they have had some experience of working with circles and have a feeling for the meaning of the relationship $C = \pi d = 2\pi r$ and know how to use the π key on their calculator.

Question 1a asks for a prediction. In fact, most people (adults as well as students) will incorrectly predict that 5 metres added to the length of a rope encircling the Earth will make an imperceptible difference. This is because they are thinking in terms of the ratio of the extended circumference to the original circumference: if we add 5 metres to 40 000 kilometres, we are extending the circumference by only $\frac{1}{8\,000\,000}$ of its original length.

There is, however, another ratio at work here, and that is the ratio of circumference to diameter (π). This ratio tells us that, for every unit we add to the diameter, we add a little over 3 units (π) to the circumference. Working this in reverse, we can see that for every 3 units (roughly) that we add to the circumference, we add 1 unit to the diameter. So, estimating the answer to question 1b, if we increase the circumference by 5 metres, we get an increase in diameter of about $5 \div 3$, which is about 1.5 metres. If the rope is to be suspended evenly above the spherical surface of the Earth (as the question assumes), it would stand about 0.75 metres (half of 1.5 metres) above the surface. The diagram on the following page illustrates this situation, using the more accurate value of 1.59 metres for the increase in diameter:

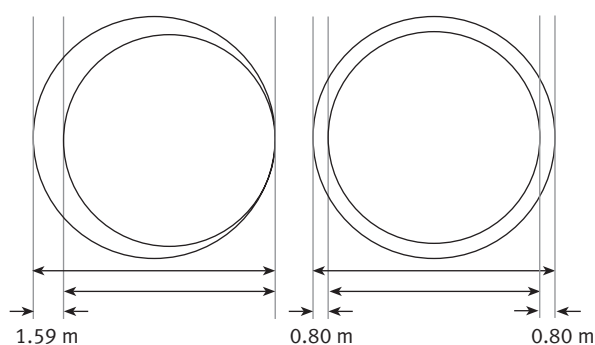

The Answers give a deductive method for question 2, and it is best that the students follow this approach. But some may realise that if the rope stands 2 metres above the surface, this is equivalent to adding 4 metres to the diameter, which means that the circumference increases by $4 \times \pi = 12.57$ metres. It's that easy! (This answer, rounded to 4 significant figures, is one figure different from the given answer because there has been no need to round during the calculation.)

If the students have difficulty accepting their findings, it may help if they run string around a hula hoop laid on the tennis courts, then add a small amount of length to the string, and see how "loose" the circumference becomes.

ACTIVITY TWO

This activity tells the students to use a spreadsheet formula and gives them the key information they need to do this. If they are not comfortable with the use of computers for this purpose, they are likely to lose the point of the activity because their focus will be on using the tools. There are no special difficulties involved in creating the graph required for question 1iii.

You should discuss the completed graph with your students and help them understand what it means. The graph is a straight line, showing that the relationship between the radius or diameter and the circumference is *linear*. No matter what the radius is, if you increase it by 1 unit, the circumference increases by 2π units (approximately 6.28 units). This is what the students should discover and describe in question 2.

Pages 18–19 On the Right Track

Achievement Objectives

- calculate perimeters of circles, rectangles, and triangles, areas of rectangles, and volumes of cuboids from measurements of length (Measurement, level 4)
- make sensible estimates and check the reasonableness of answers (Number, level 4)
- write and solve problems involving decimal multiplication and division (Number, level 4)
- round numbers sensibly (Number, level 5)

ACTIVITY

This activity features an annual school event that has considerable mathematical potential, the marking out of the athletics track. In practice, the groundsperson or the caretaker usually does this using string, pegs, and a long tape and follows a process that gives a correct result without much calculation. In this activity, the students have to use their understanding of the π relationship to answer questions and draw scale diagrams of the oval track and an alternative circular track.

The students should not find questions 1 and 2 difficult as long as they realise that each of the 4 sections of the inside track (2 straights and 2 semicircles) are exactly 100 metres long. (See the illustration in the Answers.) They will have a problem with question 3b if they don't notice that the width of the lanes is given in centimetres rather than metres. Note that they are not asked to draw in all the individual lanes on the scale diagram. This is because the scale they are using is too small.

In question 4, the students may be tempted to use the outer edge of lane 8, as constructed in question 3, but runners do not use the outer edge because they know that the distance around the inner edge is less. Students who have worked through and understood the previous activity, Round the Bend (page 17 of the students' book), may realise that, as the diameter of the inside of lane 8 is $2 \times 5.25 = 10.5$ metres greater than the inside of lane 1, the extra length involved can be simply calculated in this way: $10.5 \times \pi = 33.0$ metres (rounded to 3 significant figures). (7 lanes each 0.75 metres wide give a total width of $7 \times 0.75 = 5.25$ metres.)

Although the students could calculate the answers to question 5 using proportion and a protractor, you should suggest that they use string or a thin strip of card to mark the curved distances.

In question 6, they find the area of the rectangle and circle and add them together. In question 7, they find the diameter of the circle and then use it to calculate the area. They can compare the two areas in a number of ways, but however they do it, encourage them to express their comparison in suitably rounded numbers.

In questions 8 and 9, the students apply processes similar to those used in questions 3–5, this time to a circular track.

If the students are doing this activity prior to their own school athletics track being marked, they may be able to help the caretaker set out the marker pegs for each lane or they may be able to set the markers out themselves and have the caretaker check them before painting in the start lines.

Note that, in most cases, the students need to round their answers when working through this activity. Because the degree or method of rounding is not specified, they may end up with answers that are a little different from those in the Answers. If they get different answers, don't assume that rounding is the reason. And don't inadvertently give the impression that as long as their answers are somewhere in the ballpark, this is good enough. Many students struggle to understand the meaning and value of rounding and need a lot of careful coaching.

CROSS CURRICULAR LINKS

Physical Education and Health

This activity could be part of a unit based around running, jumping, and throwing.

Achievement Objectives

- acquire and apply complex motor skills by using basic principles of motor learning (Movement Concepts and Motor Skills, level 5)
- investigate and practise safety procedures and strategies to minimise risk and to manage risk situations (Personal Health and Physical Development, level 5)

Pages 20–21 Gumboot Games

Achievement Objectives

- carry out measuring tasks involving reading scales to the nearest gradation (Measurement, level 4)
- interpret and use information about rates presented in a variety of ways, for example, graphically, numerically, or in tables (Measurement, level 5)
- interpret information and results in context (Mathematical Processes, developing logic and reasoning, level 4)
- make conjectures in a mathematical context (Mathematical Processes, developing logic and reasoning, level 4)

In these activities, the students explore mass and distance and, using ratio, develop simple ideas related to density and aerodynamics. They do some outdoor, practical experimentation, weighing, throwing, measuring, and recording.

ACTIVITY ONE

Question 1 challenges the students to compare distances expressed in three different units.

In question 2, they revisit the volume/mass equivalence that they explored in several activities in *Measurement: Book One, Figure It Out, Years 7–8*.

In question 3, the students must round up because of the practical realities of the situation. Discuss this with the class because, in everyday life, this kind of rounding is commonplace: you can't hire 1.25 taxis to carry 5 people, and you can't buy 1.4 cans of tomato paste when a recipe calls for this amount.

ACTIVITY TWO

Question 1 asks the students to predict before they calculate. Suggest that they round their calculations to 3 decimal places (as in the Answers).

In question 1d, the students should make a statement that is consistent with *all* their data. Most will write a statement that says the heavier the object, the lower the throw rate. Some may also discuss the aerodynamics of the objects.

In question 2, the students collect their own data and see if it is consistent with the information they were originally given. With all this throwing about to take place, make sure that everyone is clear on the safety rules and that the activity is well supervised. If time permits, the students could throw each object a number of times and then find the average distance covered. If they throw a wide variety of objects, they are likely to find their earlier hypothesis challenged by very light objects, and they may want to replace it with one that says there is an optimum mass that gives a maximum throw rate.

INVESTIGATION

The answer to this question is a complex interplay of factors. The students need to explore aerodynamics, mass, and density. They can bring their own experiences and observations to a discussion on this issue. Very light objects are very subject to air resistance (which is why they blow around so easily in a wind). Many students know that if they screw a piece of paper into a tight ball or make it into a dart, it will go further. This is because they have reduced the air resistance (improved the aerodynamics).

For a detailed discussion of the relevant concepts, see Building Science Concepts Book 30, *The Air Around Us* and Book 34, *Parachutes*.

CROSS-CURRICULAR LINKS

Science

This activity could be part of a unit on aerodynamics. The students could design paper planes and then adjust one variable at a time to see how each influences the distance travelled.

It could equally well be part of a unit about flight. The students could investigate things that fly (for example, birds, bats, insects, sycamore seeds, dandelion seeds, hot-air balloons, helicopters, and gliders) and explore how mass, density, and aerodynamics all play a part in enabling the creature or thing to defy gravity.

See also Building Science Concepts Book 17, *Flight* (published term 3, 2004).

For two excellent websites see The Beginner's Guide to Aerodynamics:

www.grc.nasa.gov/WWW/K-12/airplane/bga.html

and Paper Plane Aerodynamics: www.paperplane.org/paero.html

All About Flight is a video made for school students that explains how an aeroplane gets off the ground, flies through the air, and then lands safely. For information, see www.teamvideo.net/science.htm

Achievement Objectives

- investigate and offer explanations for commonly experienced physical phenomena and compare their ideas with scientific ideas (Making Sense of the Physical World, level 4)
- carry out simple practical investigations, with control of variables, into common physical phenomena, and relate their findings to scientific ideas (Making Sense of the Physical World, level 5)

Achievement Objectives

- read and construct a variety of scales, timetables, and charts (Measurement, level 4)
- perform calculations with time, including 24-hour clock times (Measurement, level 4)
- sketch and interpret graphs on whole number grids which represent simple everyday situations (Algebra, level 4)
- interpret and use information about rates presented in a variety of ways, for example, graphically, numerically, or in tables (Measurement, level 5)

ACTIVITY ONE

This activity has a lot of information for the students to read and absorb before they can enter it in a roster. They will learn most if you leave them to sort the details out for themselves, but you may need to help any who have trouble with reading.

The students should start by entering the times and activities from the bullet-point list and then add the student and adult rosters. They need to be able to move between 12 and 24 hour time and to convert minutes into hours. A complicating factor is that the lines on the chart won't all represent equal time intervals.

ACTIVITY TWO

This activity relates to the rate at which fuel is fed into a kiln. Question 1 is best done as a spreadsheet so that the data can be used to make the graph required for question 3. Three columns are required:

- Time at 1 hour intervals (24 hour)
- Stakes burnt per hour
- Total stakes burnt. A formula could be used to add these.

If the students are using a computer to create the graph, they should choose the (XY) scatter graph option.

The number of stakes fed into the fire (question 2) never gets below 2 because of the rounding up. 60 percent of 2 is 1.2, but 1.2 rounded up becomes 2. Questions 4 and 5 ask the students to interpret their graphs. The steeper the slope is, the faster the rate at which the stakes are burnt.

CROSS-CURRICULAR LINKS

This activity could form part of an art or technology unit on pottery.

Achievement Objectives

Art

- Students will apply knowledge of elements and principles to make objects and images, using art-making conventions and a variety of techniques, tools, materials, processes, and procedures. (Developing Practical Knowledge in the Visual Arts, level 4)

Technology

- investigate and explain the use and operation of a range of technologies in everyday use, such as *in communications* (Technological Knowledge and Understanding, level 4)
- explain why people within specific technological areas carry out activities in particular ways, such as *preparing a hāngi; planning a local facility* (Technological Knowledge and Understanding, level 4)

Achievement Objectives

- read and construct a variety of scales, timetables, and charts (Measurement, level 4)
- interpret and use information about rates presented in a variety of ways, for example, graphically, numerically, or in tables (Measurement, level 5)

ACTIVITY

In this activity, the students make a simple anemometer using everyday materials such as a table tennis ball, protractor, and cardboard. There is no reason why everyone in the class can't use the one large protractor. The students can draw its outline on the card, transfer the data from the table in the book to the outline, and then pass the protractor on to someone else. The figures in the table convert the degrees on the protractor into very approximate wind speeds.

The students may find that the best way to attach the nylon line to the table tennis ball is to thread it through the ball on a long needle and then knot it on the far side. They need to attach the other end of the line to the centre of the protractor. The students use the completed anemometer to record the wind speed over several days.

To use the anemometer, one student holds it so that the baseline (the 0–180 degree line) is horizontal and aligned with the direction of the wind. A second student observes and records where the line crosses the wind-speed scale. If the line is moving up and down, they should read the mid-way value.

It is best if the wind is blowing steadily when measured. In gusty conditions, the ball will blow all over the place and the students will not be able to get a consistent reading.

INVESTIGATION

Using the Internet, the students will discover that the wind chill factor concept has undergone a major overhaul in recent years. This is because the early tables did not adequately reflect the way people experience cold and wind. A useful introduction can be found at: www.nws.noaa.gov/om/windchill/windchillglossary.shtml

The formula now used to calculate wind chill looks extremely scientific and accurate, but it is only a model. Some authorities doubt its value.

CROSS-CURRICULAR LINKS**Science**

This activity could be used as part of a unit on weather measurement and observation. The students could design and make other weather instruments, such as a barometer, windsock, or weathervane, and then use them to record and forecast the weather, keeping a record of the accuracy of their predictions. This unit could also make use of the weather maps found in the daily newspaper.

A useful website is www.schools.ash.org.au/paal/instruments.htm It has a downloadable booklet of 22 activities that investigate air pressure and weather.

Achievement Objective

- investigate major factors and patterns associated with weather, and use given data to predict weather (Making Sense of Planet Earth and Beyond, level 4)

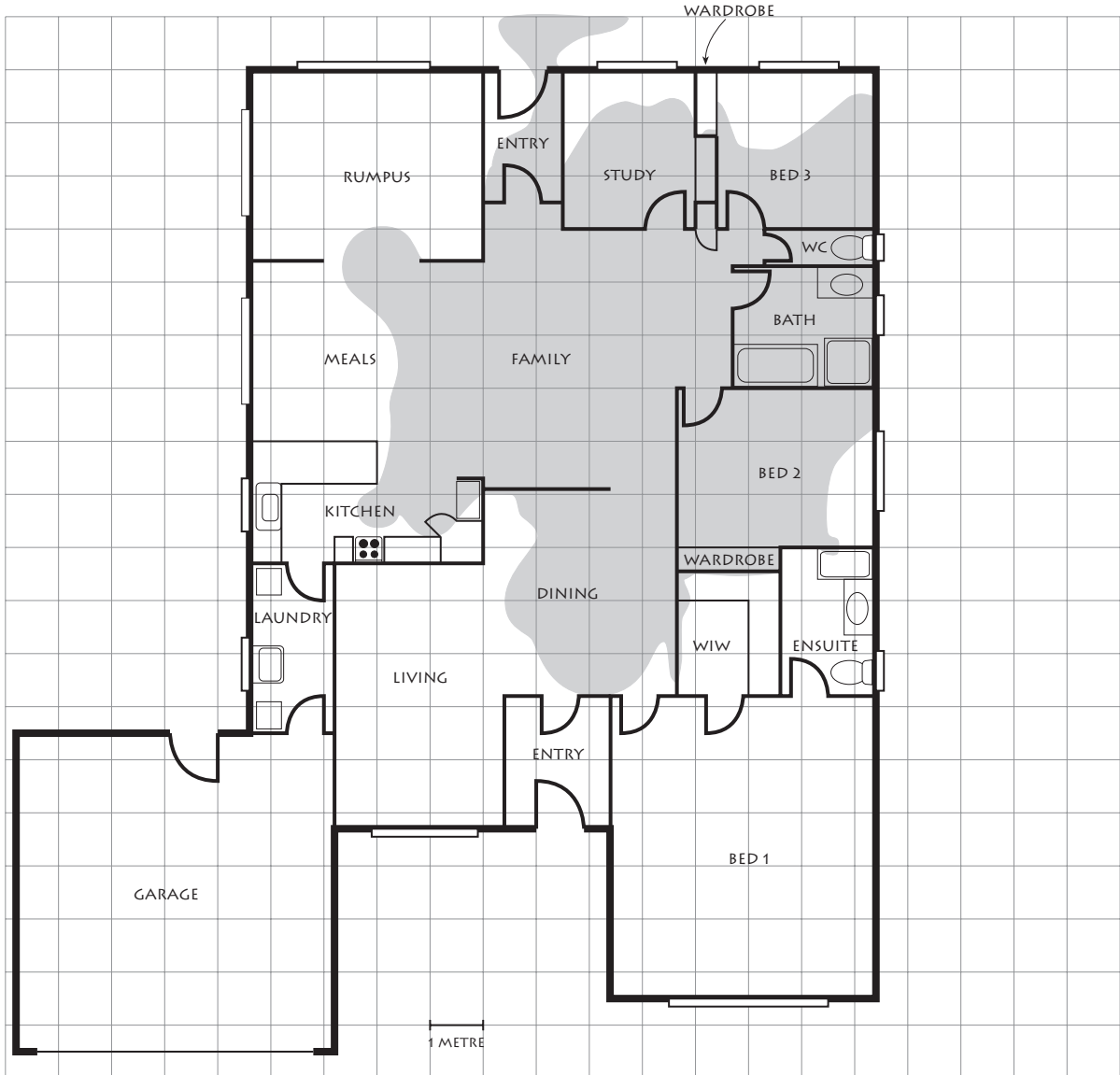

ACKNOWLEDGMENTS

Learning Media and the Ministry of Education would like to thank Len Cooper, mathematics consultant, Auckland, for developing these teachers' notes.

The photographs of the students on the cover and the multilink cubes in the side strip on page 2 are by Mark Coote and Adrian Heke. The photograph in the side strip on page 9 is by Bunkhouse graphic design.

These photographs and all illustrations are copyright © Crown 2004.

The image behind the students on the cover is from the *EtherealNet* image disc copyright © Eyewire 2000. The food in the side strip on page 1 is from the *Freie Objekte* image disc copyright © Creativ Collection.

Series Editor: Susan Roche

Editor: Ian Reid

Series Designer: Bunkhouse graphic design

Published 2004 for the Ministry of Education by
Learning Media Limited, Box 3293, Wellington, New Zealand.

Copyright © Crown 2004

All rights reserved. Enquiries should be made to the publisher.

Dewey number 530.8

ISBN 0 7903 0162 8

Item number 30162

Students' book: item number 30156