

Divide and Conquer

Division Strategies

AC

EA

AA

AM

AP

Lucky Dip?

We are learning to practise divisibility rules.

400 15 18 99

87 108

35 300

63 70

90 200

45 24 64

12 93 125

75

Exercise 1

Find the numbers from above that are:

- 1) Divisible by 100
- 2) Divisible by 10
- 3) Divisible by 5
- 4) Divisible by 2
- 5) Divisible by 3

Division Strategies

AC

EA

AA

AM

AP

Pick a Pair

We are learning to make correct division sentences.

Exercise 2

Use the numbers written below to make a correct maths sentence.

3 4 5 6 7 8 9 40 60 70 80

Do all the work in your head.

Show them like the example below.

Question: $90 \div 10 = \square$ Answer: $90 \div 10 = 5$

1) $80 \div 10 = \square$

(2) $\square \div \square = 16$

3) $120 \div 20 = \square$

(4) $4,900 \div \square = \square$

5) $\square \div 20 = 3$

(6) $\square \div \square = 2$

7) $72 \div \square = 8$

(8) $120 \div 30 = \square$

9) $\square \div 10 = 3$

(10) $420 \div \square = 60$

11) $180 \div 60 = \square$

(12) $\square \div \square = 8$

13) $32 \div 8 = \square$

(14) $560 \div \square = 80$

15) $210 \div 70 = \square$

(16) $450 \div \square = 50$

17) $160 \div \square = 4$

(18) $240 \div \square = 40$

19) $60 \div \square = 15$

(20) $4,800 \div \square = 60$

Division Strategies

Find the Family

We are learning to link multiplication and division facts.

Exercise 3

For each of the following groups of numbers write as many division facts as you can

For example, using {10, 2, 30, 120, 4, 5}

$$120 \div 30 = 4 \quad 10 \div 2 = 5 \quad 4 \div 2 = 2$$

- 1) {40, 20, 10, 8, 5, 4, 2}
- 2) {3, 4, 5, 6, 10, 15, 20, 60}
- 3) {100, 50, 25, 5, 4, 2}
- 4) {120, 40, 10, 30, 20, 4, 6, 5, 2, 24, 12, 3, 60}
- 5) {2, 4, 5, 8, 10, 16, 20, 40, 80}
- 6) {2, 5, 7, 10, 14, 25, 35}
- 7) {2, 4, 5, 8, 16, 20, 32, 40, 64, 80}
- 8) {180, 30, 90, 20, 10, 15, 18, 9, 6, 5, 3, 2}
- 9) {64, 16, 8, 40, 80, 2, 5, 4, 32, 160, 10}
- 10) {90, 60, 45, 15, 5, 3, 4, 2, 30, 9, 10}

AC

EA

AA

AM

AP

Division Strategies

Multiplication Squares

We are practising using reversibility and factors of numbers up to 100.

Exercise 4

Fill in the gaps in these multiplication squares.

AC

EA

AA

AM

AP

1)

x				2
			18	
	40			16
4		16		
	35		42	

(2)

x	10		3	
		15		
8				32
9		45		
				24

(3)

x	4			
		6	18	
		24		8
	12			
	20		45	

4)

x		4		3
		36		
	14			6
6			36	
		20		

(5)

x	7			
			15	10
	28	16		
			9	
		32	24	

(6)

x				6
	35			
2	14		20	
		12		
	63	27		

7)

x				
		8		9
	18	48		
4				36
	21		28	

(8)

x				
	64		16	
	56			
			8	40
		18	12	

(9)

x				
		15		12
	12		16	
		25		
	42			28

Division Strategies

AC

EA

AA

AM

AP

Dividagons

We are practising to use factors.

Exercise 5

Complete the triangle. The number in each square is the product of the two numbers in the circles on either side.

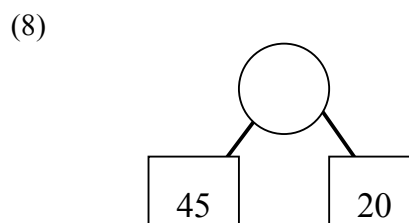
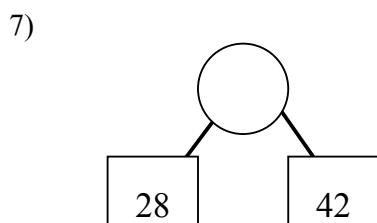
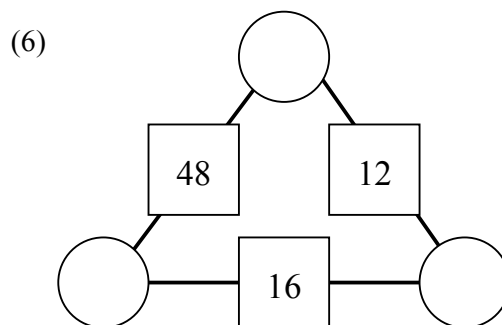
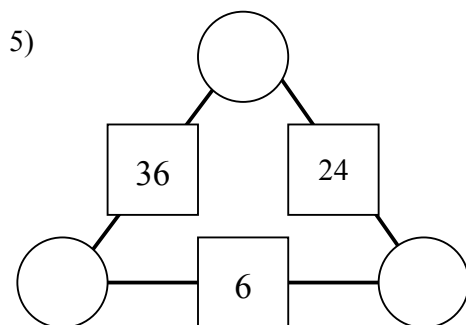
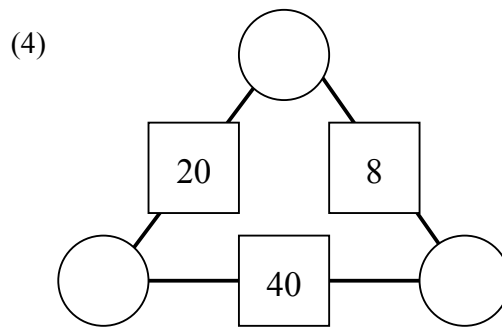
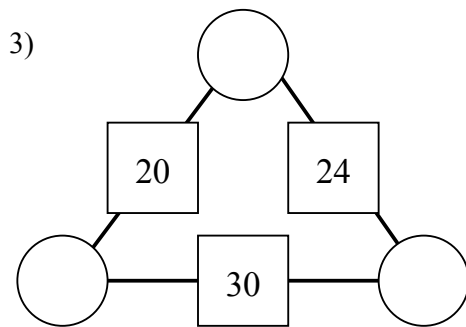
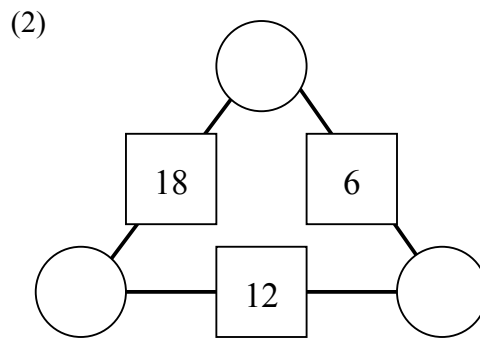
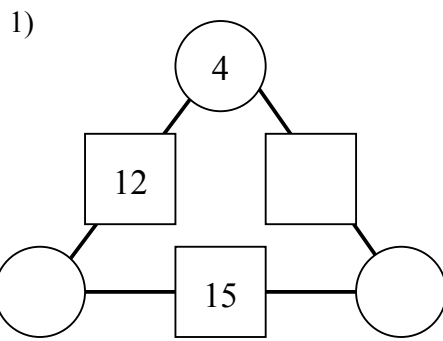

9)

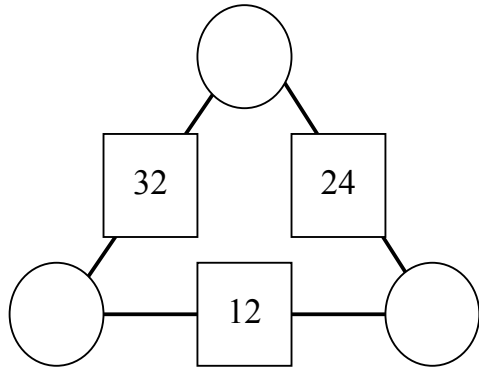

(10)

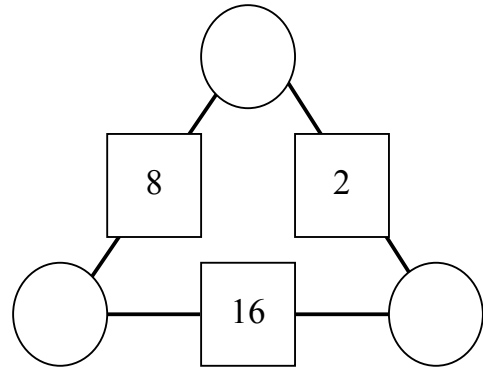

11)

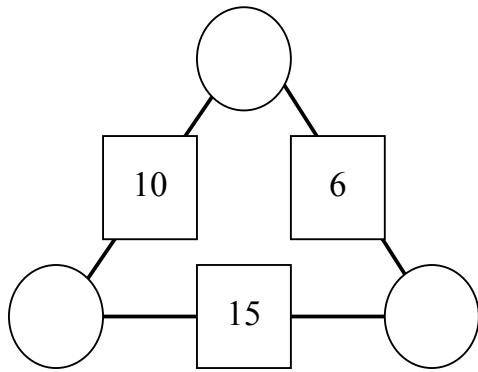

(12)

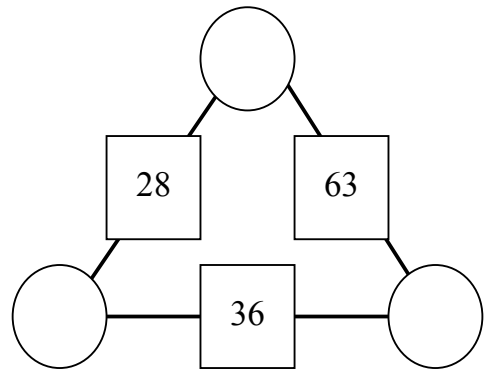

13)

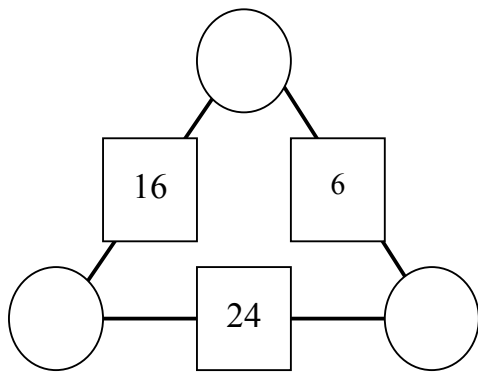

(14)

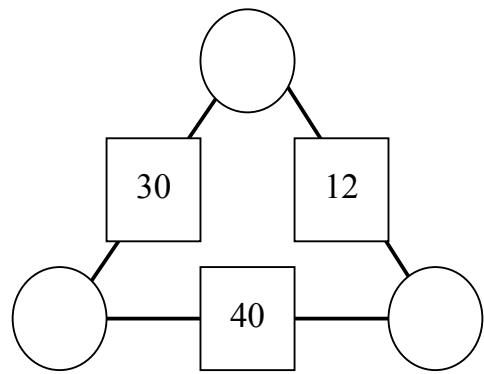

15)

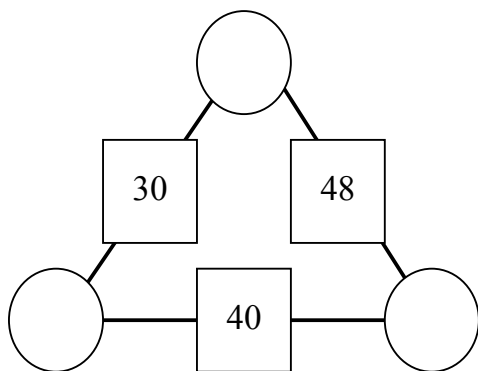

(16)

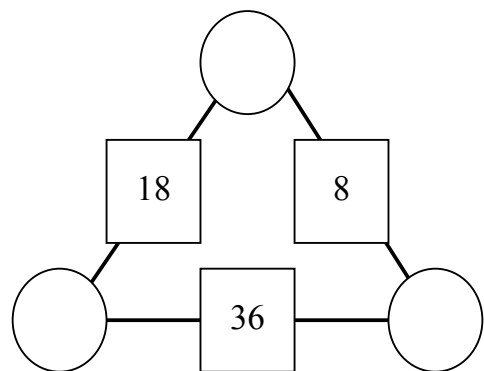

Division Strategies

Multiples and Factors

We are learning divisibility rules.

AC

EA

AA

AM

AP

Exercise 6

- 1) Using a hundreds board do the following:
 - a) Place a single coloured counter over the multiples of two.
 - b) Take another coloured counter and place over the multiples of four.
 - c) Describe what you notice?
 - d) What is the lowest common multiple of two and four?
 - e) What is the highest common factor of two and four?
- 2) On another hundreds board repeat all of question one for the multiples of three and nine. Use different coloured counters.
- 3) On a third hundreds board repeat question one for the multiples of two and nine. Use different coloured counters.
- 4) Using a hundreds board do the following:
 - f) Place a single coloured counter over the multiples of three.
 - g) Take another coloured counter and place over the multiples of six.
 - h) Describe what do notice?
 - i) What is the lowest common multiple of three and six?
 - j) What is the highest common factor of three and six?
- 5) On another hundreds board repeat all of question five for the multiples of four and eight. Use different coloured counters.
- 6) On a third hundreds board repeat all of question five for the multiples of three and eight. Use different coloured counters.
- 7) Explore the relationship between the lowest common multiple and the highest common factor for each pair of numbers.

--

- 8) Use the four digits in part a) and b) to make the answer to the following division problem a whole number.

$$\square \square \square \div \square$$

a) 1, 3, 5, 9

(b) 2, 4, 6, 8

Division Strategies

Fun with Factors

We are practicing using division facts to solve problems.

Exercise 7

Solve the following problems:

- 1) Find some numbers that have all their factors except 1, even. Describe the set of numbers.
- 2) Find some numbers that have exactly half their factors even. Describe the set of numbers.
- 3) What is the smallest number that leaves a remainder of 1 when divided by 2, 3, 4, 5, 6, 8, 10 but no remainder when it is divided by 11?
- 4) What is the smallest number that leaves a remainder of 1 when it is divided by the first three prime numbers but no remainder when it is divided by the fourth prime number?
- 5) Two numbers multiply to give an answer of 1 000 000. Neither of the numbers contains any zeros. What are the two numbers?
- 6) There are some rabbits and some rabbit hutches. If one rabbit is put in each rabbit hutch, one rabbit is left over. If two rabbits are put in each rabbit hutch, one hutch is left empty. How many rabbits and how many hutches?
- 7) There are some rabbits and some rabbit hutches. If seven rabbits are put in each rabbit hutch, one rabbit is left over. If nine rabbits are put in each rabbit hutch, one hutch is left empty. How many rabbits and how many hutches?
- 8) Use the digits 0, 1, 2, 3, 4, 5, 6, 7, 8 and 9 to form five 2 digit numbers which are all multiples of three.

AC

EA

AA

AM

AP

Division Strategies

Do it in your head

We are practising doing division mentally and recognising 'nice' numbers.

Exercise 8

LOOK at the example and SAY the answer.

- | | |
|------------------|-------------------|
| 1) $248 \div 2$ | (2) $180 \div 6$ |
| 3) $999 \div 9$ | (4) $250 \div 5$ |
| 5) $482 \div 2$ | (6) $405 \div 5$ |
| 7) $369 \div 9$ | (8) $246 \div 6$ |
| 9) $497 \div 7$ | (10) $480 \div 8$ |
| 11) $728 \div 8$ | (12) $842 \div 2$ |
| 13) $357 \div 7$ | (14) $300 \div 6$ |
| 15) $560 \div 8$ | (16) $720 \div 9$ |
| 17) $963 \div 3$ | (18) $300 \div 3$ |
| 19) $108 \div 2$ | (20) $355 \div 5$ |
| 21) $368 \div 4$ | (22) $642 \div 2$ |
| 23) $888 \div 8$ | (24) $484 \div 4$ |
| 25) $639 \div 3$ | (26) $486 \div 6$ |
| 27) $816 \div 4$ | (28) $369 \div 3$ |
| 29) $129 \div 3$ | (30) $648 \div 8$ |

AC

EA

AA

AM

AP

Division Strategies

Division by Partitioning

We are learning to use the distributive property for division.

Exercise 9

Ruwani knows she can work out the answer to $72 \div 4$ by breaking 72 into two parts that can be easily divided by 4.

$$\begin{aligned}72 \div 4 &= 40 \div 4 + 32 \div 4 \\ &= 10 + 8 \\ &= 18\end{aligned}$$

AC
EA
AA
AM
AP

What number goes in the \square ?

- 1) $36 \div 3 + 60 \div 3 = \square \div 3$
- 2) $60 \div 6 + 18 \div 6 = \square \div 6$
- 3) $30 \div 3 + 24 \div 3 = \square \div 3$
- 4) $\square \div 4 = 100 \div 4 + 12 \div 4$
- 5) $\square \div 5 = 100 \div 5 + 35 \div 5$
- 6) $70 \div 7 + 21 \div 7 = \square \div 7$
- 7) $60 \div 3 + 24 \div 3 = \square \div 3$
- 8) $90 \div 9 + 54 \div 9 = \square \div 9$
- 9) $80 \div 8 + 40 \div 8 = \square \div 8$
- 10) $27 \div 3 + 30 \div 3 = \square \div 3$
- 11) $\square \div 4 = 120 \div 6 + 12 \div 6$
- 12) $\square \div 4 = 100 \div 4 + 132 \div 4$

Use Ruwani's method to calculate the following:

- 1) $68 \div 4$
- 2) $128 \div 4$
- 3) $145 \div 5$
- 4) $102 \div 6$
- 5) $117 \div 9$
- 6) $184 \div 8$
- 7) $76 \div 4$
- 8) $87 \div 3$
- 9) $108 \div 6$
- 10) $48 \div 3$
- 11) $90 \div 6$
- 12) $168 \div 7$

Division Strategies

Division Using Tidy Numbers

We are learning to divide by rounding to a tidy number and then compensating.

Exercise 10

Jenna is putting tulip bulbs into bags for sale at the market. She has to put three bulbs into each bag. She has 84 bulbs and wants to know how many bags she will need.

Jenna knows that if she had 90 bulbs she would need 30 bags since $90 \div 3 = 30$.

She then thinks

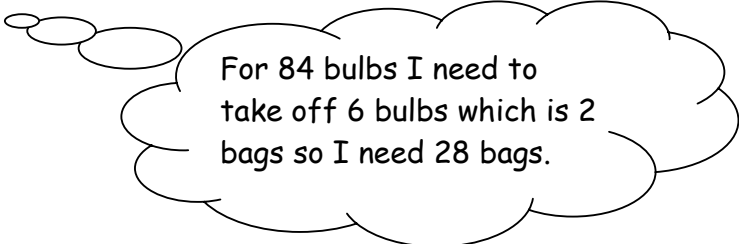

For 84 bulbs I need to take off 6 bulbs which is 2 bags so I need 28 bags.

So $84 \div 3 = 90 \div 3 - 6 \div 3$

Use Jenna's method to calculate the following:

1) $54 \div 3$

(2) $72 \div 4$

(3) $114 \div 6$

4) $76 \div 4$

(5) $111 \div 3$

(6) $291 \div 3$

7) $392 \div 4$

(8) $495 \div 5$

(9) $594 \div 6$

10) $145 \div 5$

(11) $87 \div 3$

(12) $133 \div 7$

AC

EA

AA

AM

AP

Division Strategies

AC
EA
AA
AM
AP

Dividing and Dividing

We are learning to divide by dividing by a pair of factors of the divisor.

Exercise 11

Task 1

Tevita knows he can work out the answer to $72 \div 4$ by dividing by 2 and dividing by 2 again.

$$72 \div 2 = 36 \text{ and } 36 \div 2 = 18$$

$$\text{so } 72 \div 4 = 18$$

Use Tevita's method to calculate the following:

- | | | |
|-----------------|------------------|-------------------|
| 1) $300 \div 4$ | (2) $128 \div 4$ | (3) $92 \div 4$ |
| 4) $184 \div 4$ | (5) $500 \div 4$ | (6) $104 \div 4$ |
| 7) $140 \div 4$ | (8) $56 \div 4$ | (9) $42 \div 4$ |
| 10) $90 \div 4$ | (11) $66 \div 4$ | (12) $700 \div 4$ |

Carla knows that dividing by 6 is the same as dividing by 3 and then dividing the answer by 2.

To work out $90 \div 3$ she works out $90 \div 3 = 30$ then $30 \div 2 = 15$ so $90 \div 3 = 15$

She wonders if she does the division in a different order whether she will get the same answer.

$$90 \div 2 = 45 \text{ and } 45 \div 3 = 15$$

$$\text{so } 90 \div 6 = 15$$

Task 2

Use Carla's method to calculate the following:

(Sometimes you will find it easier to divide by 3 first and other times it might be easier to divide by 2 first.)

1) $96 \div 6$

(2) $150 \div 6$

(3) $84 \div 6$

4) $132 \div 6$

(5) $450 \div 6$

(6) $336 \div 6$

Dividing by 2 and then dividing by 2 again is the same as dividing by 4.

Dividing by 3 and then dividing by 2 is the same as dividing by 6.

Ashley wonders if this rule works for other numbers as well.

Ashley knows that $120 \div 12 = 10$ so he wonders if he will get the same answer if he divides by 3 and then divides by 4 since $3 \times 4 = 12$.

$120 \div 3 = 40$ and $40 \div 4 = 10$ so it seems to work.

He decides to check it out for some other numbers he knows as well.

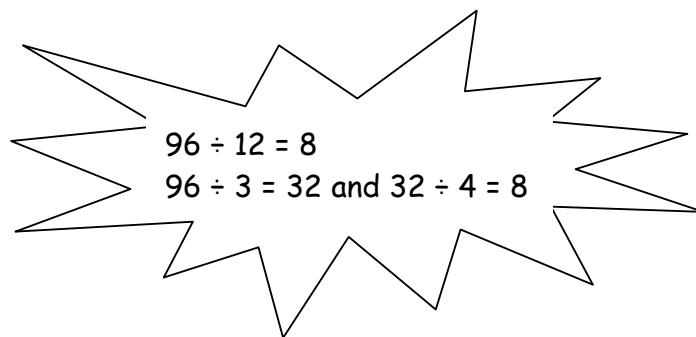

$96 \div 12 = 8$
 $96 \div 3 = 32$ and $32 \div 4 = 8$

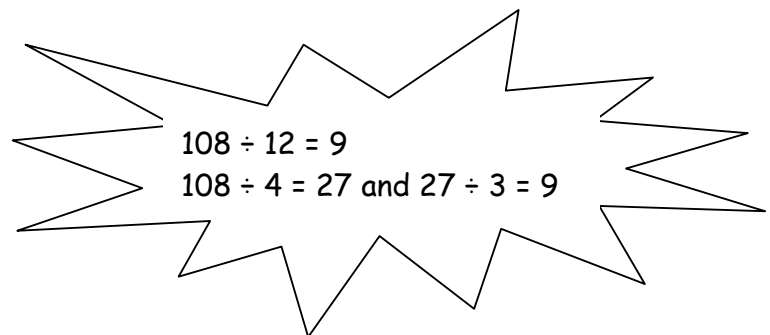

$108 \div 12 = 9$
 $108 \div 4 = 27$ and $27 \div 3 = 9$

So dividing by 3 and then dividing by 4 **is the same as** dividing by 12.

Task 3

What number goes in the box?

1) $155 \div 5 \div 2 = 155 \div \square$

(2) $114 \div 2 \div 2 = 114 \div \square$

3) $180 \div 3 \div 4 = 180 \div \square$
 \square

5) $144 \div 2 \div 3 = 144 \div \square$

7) $125 \div 5 \div 5 = 125 \div \square$

9) $600 \div 2 \div 2 \div 3 = 600 \div \square$

(4) $128 \div 2 \div 2 \div 2 = 128 \div$

(6) $243 \div 3 \div 3 = 243 \div \square$

(8) $450 \div 3 \div 2 = 450 \div \square$

(10) $130 \div 10 \div 2 = 130 \div \square$

Division Strategies

Div 4 Grid

We are learning to match word problems to number sentences.

Exercise 12

<p>There are 45 nuts in a pack. How many will Ali, Bill and Cam get each if the nuts are shared equally?</p>	$45 \div 3 = \square$
$3 \times \square = 45$	<p>They will get 15 nuts each.</p>

AC

EA

AA

AM

AP

Bill has nine times as many cherries as Ben. If Bill has 180 cherries, how many does Ben have?

$$180 \div 9 = \square$$

$$9 \times \square = 180$$

Ben has 20 cherries

Nuts are packed in 45g bags. How many bags can be made from a bin containing 900g of nuts?

$$900 \div 45 = \square$$

$$45 \times \square = 900$$

There will be 20 bags of nuts.

Paul can open 40 oysters in 4 minutes. How many can he open in 1 minute?

$$40 \div 4 = \square$$

$$4 \times \square = 40$$

He can open 10 oysters in one minute.

Kelly has 200 cherries and Cara has 25. How many times more cherries does Kelly have than Cara?

$$200 \div 25 = \square$$

$$25 \times \square = 200$$

Kelly has 8 times as many cherries as Cara.

**How many pages
can you type in 90
minutes if you type
one page every 3
minutes?**

$$90 \div 3 = \square$$

$$3 \times \square = 90$$

**You will type 30
pages.**

Division Strategies

If you know...

We are practising using the division facts we know to work out related facts.

AC
EA
AA
AM
AP

Exercise 13

- Jane knows that $224 \div 14 = 16$
Using this, find the value of
 - $224 \div 7$
 - $224 \div 28$
 - $112 \div 14$
 - $448 \div 14$
 - $224 \div 16$
 - $112 \div 16$
- Jim knows that $264 \div 4 = 66$
Using this, what is the value of
 - $264 \div 66$
 - $264 \div 8$
 - $264 \div 12$
 - $264 \div 44$
 - $132 \div 4$
 - $528 \div 4$
- Michael knows that $288 \div 18 = 16$
Using this, what is the value of
 - $288 \div 16$
 - $288 \div 9$
 - $288 \div 36$
 - $144 \div 18$
 - $288 \div 6$
 - $288 \div 12$
- Karen knows that $270 \div 18 = 15$
Using this, what is the value of
 - $270 \div 9$
 - $540 \div 18$
 - $270 \div 6$
 - $270 \div 36$
 - $270 \div 15$
 - $135 \div 15$
- Pauline knows that $252 \div 18 = 14$
Using this, what is the value of
 - $252 \div 9$
 - $252 \div 36$
 - $504 \div 18$
 - $504 \div 36$
 - $252 \div 14$
 - $126 \div 18$
- Yung knows that $286 \div 11 = 26$
Using this, what is the value of
 - $286 \div 22$
 - $143 \div 11$
 - $286 \div 44$
 - $286 \div 26$
 - $286 \div 13$
 - $143 \div 26$
- Marewa knows that $324 \div 36 = 9$
Using this, what is the value of
 - $324 \div 18$
 - $324 \div 12$
 - $324 \div 72$
 - $324 \div 9$
 - $162 \div 9$
 - $648 \div 36$
- Aloma knows that $240 \div 15 = 16$
Using this, what is the value of
 - $480 \div 15$
 - $120 \div 15$
 - $240 \div 16$
 - $480 \div 32$
 - $240 \div 32$
 - $240 \div 5$

9) Barnaby knows that $420 \div 14 = 30$

Using this what is the value of

a) $420 \div 28$

(b) $420 \div 7$

(c) $210 \div 14$

d) $840 \div 14$

(e) $420 \div 30$

(f) $420 \div 15$

10) Francesca knows that $324 \div 54 = 6$

Using this, what is the value of

a) $324 \div 108$

(b) $324 \div 6$

(c) $324 \div 27$

d) $162 \div 54$

(e) $648 \div 54$

(f) $648 \div 27$

Division Strategies

AC
EA
AA
AM
AP

Target

We are practicing using basic facts to write division problems.

Exercise 14

Place the numbers given in the grid to get an answer as close as possible to the given target number.

- 1) $\boxed{}\boxed{} \div \boxed{}$
1, 2 and 3 Target 6
- 2) $\boxed{}\boxed{} \div \boxed{}$
2, 3 and 4 Target 7
- 3) $\boxed{}\boxed{} \div \boxed{}$
2, 3 and 5 Target 5
- 4) $\boxed{}\boxed{} \div \boxed{}$
3, 4 and 5 Target 16
- 5) $\boxed{}\boxed{} \div \boxed{}$
4, 5 and 6 Target 8
- 6) $\boxed{}\boxed{} \div \boxed{}$
6, 7 and 9 Target 11
- 7) $\boxed{}\boxed{} \div \boxed{}$
5, 6 and 8 Target 10
- 8) $\boxed{}\boxed{} \div \boxed{}$
6, 7 and 8 Target 9
- 9) $\boxed{}\boxed{} \div \boxed{}$
7, 8 and 9 Target 12
- 10) $\boxed{}\boxed{} \div \boxed{}$
2, 4 and 6 Target 8
- 11) $\boxed{}\boxed{} \div \boxed{}$
1, 3 and 5 Target 6
- 12) $\boxed{}\boxed{} \div \boxed{}$
3, 4 and 5 Target 13

Division Strategies

AC
EA
AA
AM
AP

Number Squares

We are practising recognising factors of numbers.

Exercise 15

Find the missing numbers in each number square. The number at the end of the row is the product of the numbers in that row. The number at the bottom of each column is the product of the numbers in that column.

1)

72
120
42
70 32 162
Use 1, 2, 3, ... 9 once each to fill the 9 spaces.

2)

5		
		2
	3	

20
12
30
25 18 16
Two of the hidden numbers are 1.
Four are chosen from 2, 3, 4, 5, 6 and 7.

3)

	3	
4		
		2

30
16
6
20 9 16
Two of the hidden numbers are 1.
Four are chosen from 2, 3, 4, 5, 6, 7, 8 and 9.

4)

20
12
14
6
4 15 28 12
Seven of the hidden numbers are 1.
Five are chosen from 2, 3, 4, 5, 6, 7, 8 and 9.

5)

				12
				18
				30
				16
24	10	24	18	

Seven of the hidden numbers are 2.
 The other nine numbers are chosen from 1, 3, 5, 6.

6)

			12	14400
	14			980
15				450
		9		450
900	700	5400	840	

Seven of the hidden numbers are 1.
 Five are multiples of 10 below 100.

Lucky Dip?

Answers

Exercise 1

- 1) 400, 300, 200
- 2) 400, 300, 200, 90, 70
- 3) 400, 300, 200, 125, 90, 75, 70, 45, 35
- 4) 400, 300, 200, 90, 70, 18, 108, 64, 24, 12
- 5) 300, 108, 99, 93, 90, 87, 75, 63, 45, 24, 18, 15

Pick a Pair Answers

Exercise 2

1) $80 \div 10 = 8$

3) $120 \div 20 = 3$

5) $60 \div 20 = 3$

7) $72 \div 9 = 8$

9) $30 \div 10 = 3$

11) $180 \div 60 = 3$

13) $32 \div 8 = 4$

15) $210 \div 70 = 3$

17) $160 \div 40 = 4$

19) $60 \div 4 = 15$

(2) $80 \div 5 = 16$ or $80 \div 16 = 5$

(4) $4,900 \div 7 = 70$ or $4,900 \div 70 = 7$

(6) $80 \div 40 = 2$ or $8 \div 4 = 2$

(8) $120 \div 30 = 4$

(10) $420 \div 7 = 60$

(12) $40 \div 5 = 8$

(14) $560 \div 70 = 80$

(16) $450 \div 9 = 50$

(18) $240 \div 6 = 40$

(20) $4,800 \div 80 = 60$

Find the Family

Answers

Exercise 3

- | | | | |
|----|--|---|---|
| 1) | $40 \div 20 = 2$
$40 \div 5 = 8$
$20 \div 10 = 2$
$20 \div 2 = 10$
$8 \div 4 = 2$ | $40 \div 10 = 4$
$40 \div 4 = 10$
$20 \div 5 = 4$
$10 \div 5 = 2$
$8 \div 2 = 4$ | $40 \div 8 = 5$
$40 \div 2 = 20$
$20 \div 4 = 5$
$10 \div 2 = 5$
$4 \div 2 = 2$ |
| 2) | $60 \div 20 = 3$
$60 \div 3 = 20$
$20 \div 4 = 5$ | $60 \div 10 = 6$
$60 \div 15 = 4$
$15 \div 5 = 3$ | $60 \div 6 = 10$
$20 \div 5 = 4$ |
| 3) | $100 \div 50 = 2$
$100 \div 25 = 4$
$50 \div 2 = 25$ | $100 \div 25 = 4$
$100 \div 2 = 50$
$25 \div 5 = 5$ | $100 \div 4 = 25$
$50 \div 25 = 2$
$4 \div 2 = 2$ |
| 4) | $120 \div 40 = 3$
$120 \div 20 = 6$
$120 \div 6 = 20$
$120 \div 3 = 40$
$40 \div 4 = 10$
$30 \div 6 = 5$
$24 \div 6 = 4$
$20 \div 10 = 2$
$20 \div 2 = 10$
$12 \div 3 = 4$
$10 \div 2 = 5$
$4 \div 2 = 2$ | $120 \div 30 = 4$
$120 \div 12 = 10$
$120 \div 5 = 24$
$40 \div 20 = 2$
$40 \div 2 = 20$
$30 \div 5 = 6$
$24 \div 4 = 6$
$20 \div 5 = 4$
$12 \div 6 = 2$
$12 \div 2 = 6$
$6 \div 3 = 2$ | $120 \div 24 = 5$
$120 \div 10 = 12$
$120 \div 4 = 30$
$40 \div 10 = 4$
$30 \div 10 = 3$
$30 \div 3 = 10$
$24 \div 2 = 12$
$20 \div 4 = 5$
$12 \div 4 = 3$
$10 \div 5 = 2$
$6 \div 2 = 3$ |
| 5) | $80 \div 40 = 2$
$80 \div 10 = 8$
$80 \div 4 = 20$
$40 \div 10 = 4$
$40 \div 4 = 10$
$20 \div 5 = 4$
$16 \div 8 = 2$
$10 \div 5 = 2$
$8 \div 2 = 4$ | $80 \div 20 = 4$
$80 \div 8 = 10$
$80 \div 2 = 40$
$40 \div 8 = 5$
$40 \div 2 = 20$
$20 \div 4 = 5$
$16 \div 4 = 4$
$10 \div 2 = 5$
$4 \div 2 = 2$ | $80 \div 16 = 5$
$80 \div 5 = 16$
$40 \div 20 = 2$
$40 \div 5 = 8$
$20 \div 10 = 2$
$20 \div 2 = 10$
$16 \div 2 = 8$
$8 \div 4 = 2$ |
| 6) | $35 \div 7 = 5$
$14 \div 7 = 2$
$10 \div 2 = 5$ | $35 \div 5 = 7$
$14 \div 2 = 7$ | $25 \div 5 = 5$
$10 \div 5 = 2$ |

- 7) $80 \div 40 = 2$ $80 \div 20 = 4$ $80 \div 16 = 5$
 $80 \div 8 = 10$ $80 \div 5 = 16$ $80 \div 4 = 20$
 $80 \div 2 = 40$ $64 \div 32 = 2$ $64 \div 16 = 4$
 $64 \div 8 = 8$ $64 \div 4 = 16$ $64 \div 2 = 32$
 $40 \div 20 = 2$ $40 \div 8 = 5$ $40 \div 5 = 8$
 $40 \div 2 = 20$ $32 \div 16 = 2$ $32 \div 8 = 4$
 $32 \div 4 = 8$ $32 \div 2 = 16$ $20 \div 5 = 4$
 $20 \div 4 = 5$ $16 \div 8 = 2$ $16 \div 4 = 4$
 $16 \div 2 = 8$ $8 \div 4 = 2$ $8 \div 2 = 4$
 $4 \div 2 = 2$
- 8) $180 \div 90 = 2$ $180 \div 30 = 6$ $180 \div 20 = 9$
 $180 \div 18 = 10$ $180 \div 15 = 12$ $180 \div 10 = 18$
 $180 \div 9 = 20$ $180 \div 6 = 30$ $180 \div 2 = 90$
 $90 \div 30 = 3$ $90 \div 18 = 5$ $90 \div 15 = 6$
 $90 \div 10 = 9$ $90 \div 9 = 10$ $90 \div 6 = 15$
 $90 \div 5 = 18$ $90 \div 3 = 30$ $30 \div 15 = 2$
 $30 \div 10 = 3$ $30 \div 6 = 5$ $30 \div 5 = 6$
 $30 \div 3 = 10$ $30 \div 2 = 15$ $20 \div 10 = 2$
 $20 \div 5 = 4$ $20 \div 2 = 10$ $18 \div 9 = 2$
 $18 \div 6 = 3$ $18 \div 3 = 6$ $18 \div 2 = 9$
 $15 \div 5 = 3$ $15 \div 3 = 5$ $10 \div 5 = 2$
 $10 \div 2 = 5$ $9 \div 3 = 3$ $6 \div 3 = 2$
- 9) $160 \div 80 = 2$ $160 \div 40 = 4$ $160 \div 32 = 5$
 $160 \div 16 = 10$ $160 \div 10 = 16$ $160 \div 8 = 20$
 $160 \div 5 = 32$ $160 \div 4 = 40$ $160 \div 2 = 80$
 $80 \div 40 = 2$ $80 \div 16 = 5$ $80 \div 10 = 8$
 $80 \div 8 = 10$ $80 \div 5 = 16$ $80 \div 4 = 20$
 $80 \div 2 = 40$ $64 \div 32 = 2$ $64 \div 16 = 4$
 $64 \div 8 = 8$ $64 \div 4 = 16$ $64 \div 2 = 32$
 $40 \div 10 = 4$ $40 \div 8 = 5$ $40 \div 5 = 8$
 $40 \div 4 = 10$ $40 \div 2 = 20$ $32 \div 16 = 2$
 $32 \div 8 = 4$ $32 \div 4 = 8$ $32 \div 2 = 16$
 $16 \div 8 = 2$ $16 \div 4 = 4$ $16 \div 2 = 8$
 $10 \div 5 = 2$ $10 \div 2 = 5$ $8 \div 4 = 2$
 $8 \div 2 = 4$ $4 \div 2 = 2$
- 10) $90 \div 45 = 2$ $90 \div 30 = 3$ $90 \div 10 = 9$

 $90 \div 9 = 10$ $90 \div 3 = 30$ $90 \div 2 = 45$

 $60 \div 30 = 2$ $60 \div 15 = 4$ $60 \div 4 = 15$

 $60 \div 2 = 30$ $45 \div 15 = 3$ $45 \div 9 = 5$
 $45 \div 5 = 9$ $45 \div 3 = 15$ $30 \div 15 = 2$

$$30 \div 10 = 3$$

$$15 \div 5 = 3$$

$$10 \div 2 = 5$$

$$30 \div 3 = 10$$

$$15 \div 3 = 5$$

$$9 \div 3 = 3$$

$$30 \div 2 = 15$$

$$10 \div 5 = 2$$

$$4 \div 2 = 2$$

Multiplication Squares

Answers

Exercise 4

1)

x	5	4	6	2
3	15	12	18	6
8	40	32	48	16
4	20	16	24	8
7	35	28	42	14

(2)

x	10	5	3	4
3	30	15	9	12
8	80	40	24	32
9	90	45	27	36
6	60	30	18	24

(3)

x	4	3	9	1
2	8	6	18	2
8	32	24	72	8
3	12	9	27	3
5	20	15	45	5

4)

x	7	4	6	3
9	63	36	54	27
2	14	8	12	6
6	42	24	36	18
5	35	20	30	15

(5)

x	7	4	3	2
5	35	20	15	10
4	28	16	12	8
3	21	12	9	6
8	56	32	24	16

(6)

x	7	3	10	6
5	35	15	50	30
2	14	6	20	12
4	28	12	40	24
9	63	27	90	54

7)

x	3	8	4	9
1	3	8	4	9
6	18	48	24	54
4	12	32	16	36
7	21	56	28	63

(8)

x	8	3	2	10
8	64	24	16	80
7	56	21	14	70
4	32	12	8	40
6	48	18	12	60

(9)

x	6	5	8	4
3	18	15	24	12
2	12	10	16	8
5	30	25	40	20
7	42	35	56	28

Dividagons Answers

Exercise 5

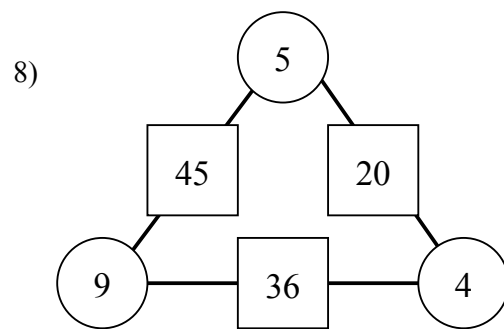
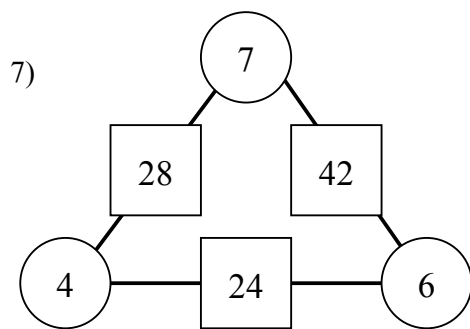
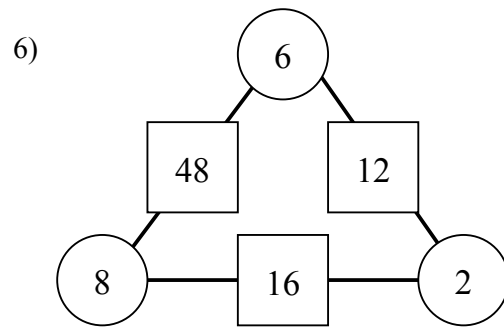
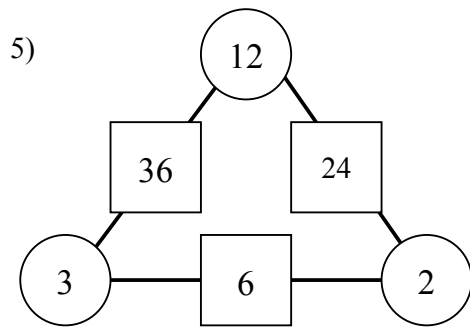
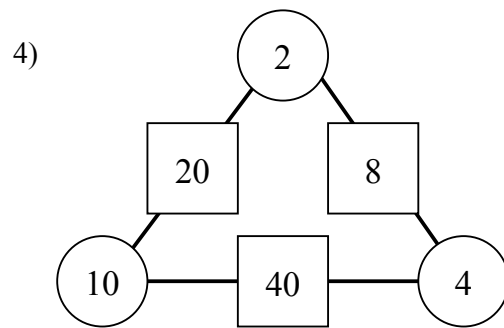
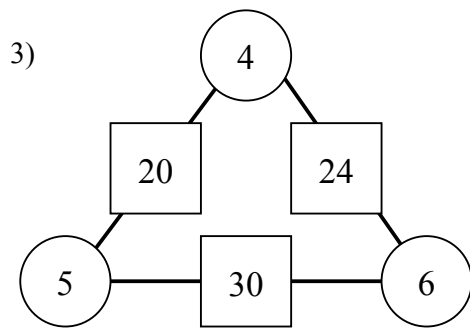
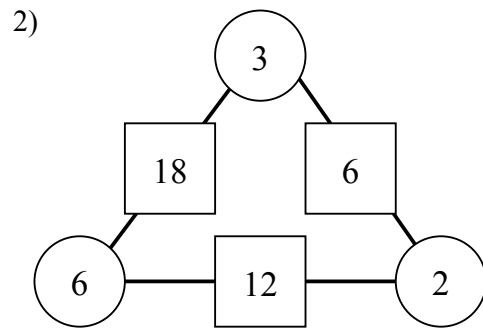
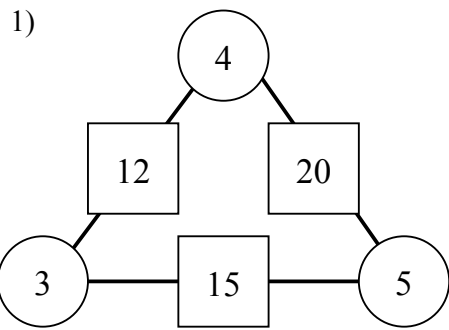

9)

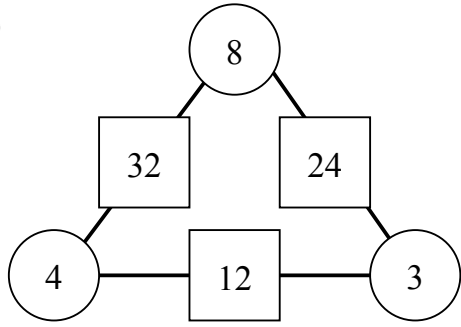

10)

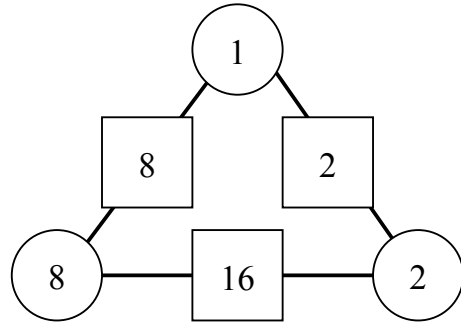

11)

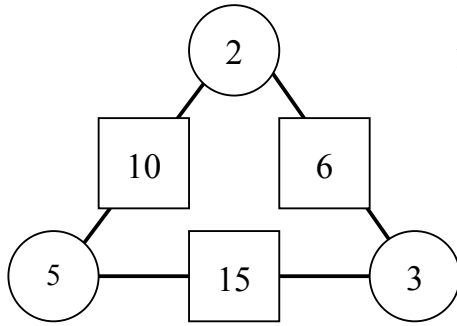

12)

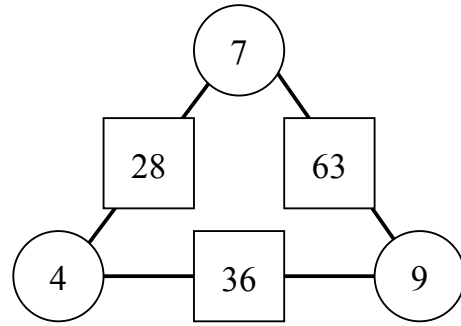

13)

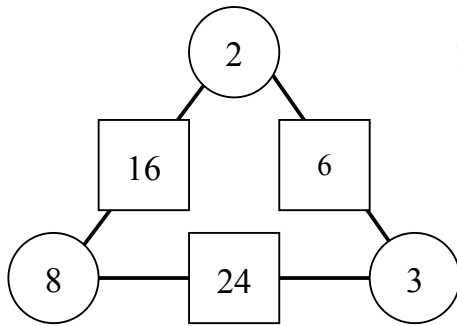

14)

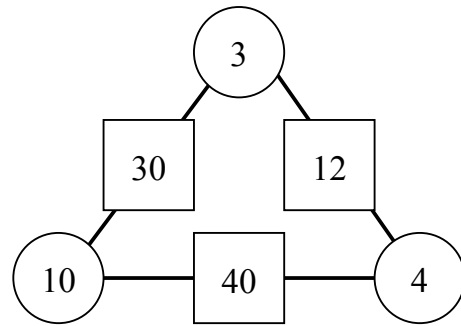

15)

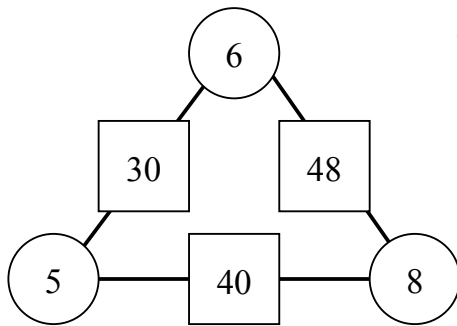

16)

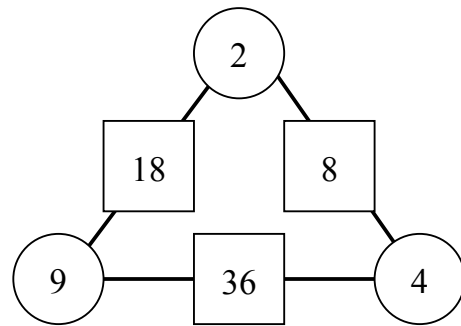

Multiples and Factors

Answers

Exercise 6

1) a) & b) Multiples of two and four.

1	2	3	4	5	6	7	8	9	10
11	12	13	14	15	16	17	18	19	20
21	22	23	24	25	26	27	28	29	30
31	32	33	34	35	36	37	38	39	40
41	42	43	44	45	46	47	48	49	50
51	52	53	54	55	56	57	58	59	60
61	62	63	64	65	66	67	68	69	70
71	72	73	74	75	76	77	78	79	80
81	82	83	84	85	86	87	88	89	90
91	92	93	94	95	96	97	98	99	100

c) All the multiples of four are also multiples of two.

d) 4

e) 2

2) a) & b) Multiples of three and nine.

1	2	3	4	5	6	7	8	9	10
11	12	13	14	15	16	17	18	19	20
21	22	23	24	25	26	27	28	29	30
31	32	33	34	35	36	37	38	39	40
41	42	43	44	45	46	47	48	49	50
51	52	53	54	55	56	57	58	59	60
61	62	63	64	65	66	67	68	69	70
71	72	73	74	75	76	77	78	79	80
81	82	83	84	85	86	87	88	89	90
91	92	93	94	95	96	97	98	99	100

c) All the multiples of nine are also multiples of three.

d) 9

e) 3

3) a) & b) Multiples of two and nine.

1	2	3	4	5	6	7	8	9	10
11	12	13	14	15	16	17	18	19	20
21	22	23	24	25	26	27	28	29	30
31	32	33	34	35	36	37	38	39	40
41	42	43	44	45	46	47	48	49	50
51	52	53	54	55	56	57	58	59	60
61	62	63	64	65	66	67	68	69	70
71	72	73	74	75	76	77	78	79	80
81	82	83	84	85	86	87	88	89	90
91	92	93	94	95	96	97	98	99	100

c) The only common multiples are the multiples of nine that are also divisible by two.

d) 18

e) 1

4) f) & g) Multiples of three and six.

1	2	3	4	5	6	7	8	9	10
11	12	13	14	15	16	17	18	19	20
21	22	23	24	25	26	27	28	29	30
31	32	33	34	35	36	37	38	39	40
41	42	43	44	45	46	47	48	49	50
51	52	53	54	55	56	57	58	59	60
61	62	63	64	65	66	67	68	69	70
71	72	73	74	75	76	77	78	79	80
81	82	83	84	85	86	87	88	89	90
91	92	93	94	95	96	97	98	99	100

h) All the multiples of six are also multiples of three.

i) 6

j) 3

5) f) & g) Multiples of four and eight.

1	2	3	4	5	6	7	8	9	10
11	12	13	14	15	16	17	18	19	20
21	22	23	24	25	26	27	28	29	30
31	32	33	34	35	36	37	38	39	40
41	42	43	44	45	46	47	48	49	50
51	52	53	54	55	56	57	58	59	60
61	62	63	64	65	66	67	68	69	70
71	72	73	74	75	76	77	78	79	80
81	82	83	84	85	86	87	88	89	90
91	92	93	94	95	96	97	98	99	100

h) All the multiples of eight are also multiples of four.

i) 8

j) 4

6) a) & b) Multiples of four and six.

1	2	3	4	5	6	7	8	9	10
11	12	13	14	15	16	17	18	19	20
21	22	23	24	25	26	27	28	29	30
31	32	33	34	35	36	37	38	39	40
41	42	43	44	45	46	47	48	49	50
51	52	53	54	55	56	57	58	59	60
61	62	63	64	65	66	67	68	69	70
71	72	73	74	75	76	77	78	79	80
81	82	83	84	85	86	87	88	89	90
91	92	93	94	95	96	97	98	99	100

h) The only common multiples are the multiples of six that are also divisible by four.

i) 12

j) 2

7) $LCM_{ab} = \frac{a \times b}{HCF_{ab}}$

8) a) $135 \div 9$

(b) $624 \div 8$

Fun with Factors

Answers

Exercise 7

- 1) Powers of two.
- 2) Even numbers that aren't powers of two.
- 3) 121
- 4) 91
- 5) 64 and 15625
- 6) 4 rabbits and 3 hutches.
- 7) 36 rabbits and 5 hutches.
- 8) There are many solutions eg. 45, 36, 27, 18, 90 or 12, 30, 75, 48, 69

Do it in your head

Answers

Exercise 8

- | | | | |
|-----|-----|------|-----|
| 1) | 124 | (2) | 30 |
| 3) | 111 | (4) | 50 |
| 5) | 241 | (6) | 81 |
| 7) | 41 | (8) | 41 |
| 9) | 71 | (10) | 60 |
| 11) | 91 | (12) | 421 |
| 13) | 51 | (14) | 50 |
| 15) | 70 | (16) | 80 |
| 17) | 321 | (18) | 100 |
| 19) | 54 | (20) | 71 |
| 21) | 92 | (22) | 321 |
| 23) | 111 | (24) | 121 |
| 25) | 213 | (26) | 81 |
| 27) | 24 | (28) | 123 |
| 29) | 43 | (30) | 88 |

Division by Partitioning Answers

Exercise 9

- | | |
|---------|----------|
| 1) 96 | (2) 78 |
| 3) 54 | (4) 112 |
| 5) 135 | (6) 91 |
| 7) 60 | (8) 54 |
| 9) 40 | (10) 30 |
| 11) 132 | (12) 232 |

Working may vary

- | | |
|----------------------------------|------------------------------------|
| 1) $40 \div 4 + 28 \div 4 = 17$ | (2) $120 \div 4 + 8 \div 4 = 32$ |
| 3) $100 \div 5 + 45 \div 5 = 29$ | (4) $60 \div 6 + 42 \div 6 = 17$ |
| 5) $90 \div 9 + 27 \div 9 = 13$ | (6) $160 \div 8 + 24 \div 8 = 23$ |
| 7) $40 \div 4 + 36 \div 4 = 19$ | (8) $60 \div 3 + 27 \div 3 = 29$ |
| 9) $60 \div 6 + 48 \div 6 = 18$ | (10) $30 \div 3 + 18 \div 3 = 16$ |
| 11) $60 \div 6 + 30 \div 6 = 15$ | (12) $140 \div 7 + 28 \div 7 = 24$ |

Division Using Tidy Numbers

Answers

Exercise 10

Working may vary

1) $60 \div 3 - 6 \div 3 = 18$

(2) $80 \div 4 - 8 \div 4 = 18$

(3) $120 \div 6 - 6 \div 6 = 19$

(4) $80 \div 4 - 4 \div 4 = 19$

(5) $120 \div 3 - 9 \div 3 = 37$

(6) $300 \div 3 - 9 \div 3 = 97$

7) $400 \div 4 - 8 \div 4 = 92$

(8) $500 \div 5 - 5 \div 1 = 99$

(9) $600 \div 6 - 6 \div 6 = 99$

(10) $150 \div 5 - 5 \div 5 = 29$

(11) $90 \div 3 - 3 \div 3 = 29$

(12) $140 \div 7 - 7 \div 7 = 19$

Dividing and Dividing Answers

Exercise 11

Task 1

- | | | |
|-----------------------------|------------------------------|--------------------------------|
| 1) 75 | (2) 32 | (3) 23 |
| 4) 46 | (5) 125 | (6) 26 |
| 7) 35 | (8) 14 | (9) 10.5 or $10\frac{1}{2}$ |
| 10) 22.5 or $22\frac{1}{2}$ | (11) 16.5 or $16\frac{1}{2}$ | (12) 175.5 or $175\frac{1}{2}$ |

Task 2

- | | | |
|-------|--------|--------|
| 1) 16 | (2) 25 | (3) 14 |
| 4) 22 | (5) 75 | (6) 56 |

Task 3

- | | | |
|--------|-------|--------|
| 1) 10 | (2) 4 | (3) 12 |
| 4) 8 | (5) 6 | (6) 9 |
| 7) 25 | (8) 6 | (9) 12 |
| 10) 20 | | |

If you know Answers

Exercise 13

- | | | |
|----------|---------|---------|
| 1) a) 32 | (b) 8 | (c) 8 |
| d) 32 | (e) 14 | (f) 7 |
| 2) a) 4 | (b) 33 | (c) 22 |
| d) 6 | (e) 33 | (f) 132 |
| 3) a) 18 | (b) 32 | (c) 8 |
| d) 8 | (e) 48 | (f) 24 |
| 4) a) 30 | (b) 30 | (c) 45 |
| d) 7.5 | (e) 18 | (f) 9 |
| 5) a) 28 | (b) 7 | (c) 28 |
| d) 14 | (e) 18 | (f) 7 |
| 6) a) 13 | (b) 13 | (c) 6.5 |
| d) 11 | (e) 22 | (f) 5.5 |
| 7) a) 18 | (b) 27 | (c) 4.5 |
| d) 36 | (e) 18 | (f) 18 |
| 8) a) 32 | (b) 8 | (c) 15 |
| d) 15 | (e) 7.5 | (f) 48 |
| 9) a) 15 | (b) 60 | (c) 15 |
| d) 60 | (e) 14 | (f) 28 |
| 10) a) 3 | (b) 54 | (c) 12 |
| d) 3 | (e) 12 | (f) 24 |

Target Answers

Exercise 14

Place the numbers given in the grid to get an answer as close as possible to the given target number.

- 1)

1	3
---	---

 \div

2

- 2)

2	4
---	---

 \div

3

- 3)

2	3
---	---

 \div

5

- 4)

4	5
---	---

 \div

3

- 5)

4	5
---	---

 \div

6

- 6)

7	9
---	---

 \div

6

- 7)

6	5
---	---

 \div

8

- 8)

6	8
---	---

 \div

7

- 9)

8	9
---	---

 \div

7

- 10)

4	2
---	---

 \div

6

- 11)

3	1
---	---

 \div

5

- 12)

5	3
---	---

 \div

4

Number Squares

Answers

Exercise 15

1)

2	4	9
5	8	3
7	1	6

72
120
42
70 32 162
Use 1, 2, 3, ... 9 once each to fill the 9 spaces.

2)

5	1	4
1	6	2
5	3	2

20
12
30
25 18 16
Two of the hidden numbers are 1.
Four are chosen from 2, 3, 4, 5, 6 and 7.

3)

5	3	2
4	1	4
1	3	2

30
16
6
20 9 16
Two of the hidden numbers are 1.
Four are chosen from 2, 3, 4, 5, 6, 7, 8 and 9.

4)

1	5	4	1
2	3	1	2
1	1	7	2
2	1	1	3

20
12
14
6
4 15 28 12
Seven of the hidden numbers are 1.
Five are chosen from 2, 3, 4, 5, 6, 7, 8 and 9.

5)

2	1	2	3	12
6	1	3	1	18
1	5	2	3	30
2	2	2	2	16
24	10	24	18	

Seven of the hidden numbers are 2.
 The other nine numbers are chosen from 1, 3, 5, 6.

6)

60	1	20	12	14400
1	14	1	70	980
15	1	30	1	450
1	50	9	1	450
900	700	5400	840	

Seven of the hidden numbers are 1.
 Five are multiples of 10 below 100.